



SUBARU Forester

2008-2009



CAN-SL-PL and TBSUBARU

Made in Canada Rev. A - 14 / 01 / 2009
Web site: <http://www.ifar.ca>

ALARM AND REMOTE STARTER CAN BUS INTERFACE KIT

Fonctionnal if equipped

<input checked="" type="checkbox"/> Lock	<input checked="" type="checkbox"/> Tach	<input type="checkbox"/> Radio Off	<input type="checkbox"/> Heat Seats
<input checked="" type="checkbox"/> Unlock	<input checked="" type="checkbox"/> Start Enable	<input type="checkbox"/> Transponder Bypass	<input type="checkbox"/> Gas Door
<input checked="" type="checkbox"/> Arm	<input checked="" type="checkbox"/> Door Trigger	<input type="checkbox"/> PK3, Passlock	<input type="checkbox"/> Window Roll Down
<input type="checkbox"/> Disarm	<input checked="" type="checkbox"/> Trunk Trigger	<input type="checkbox"/> Sliding Door	<input type="checkbox"/> Hatch
<input type="checkbox"/> Trunk	<input type="checkbox"/> Hood Trigger	<input type="checkbox"/> Defrost	<input type="checkbox"/> Brake Signal

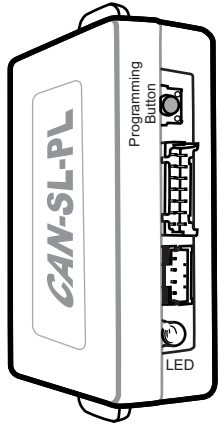

Front view of the module

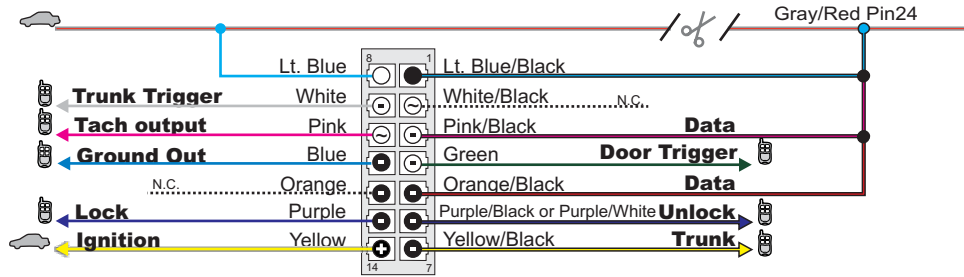

BCM located directly below the steering column.

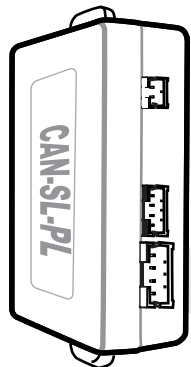
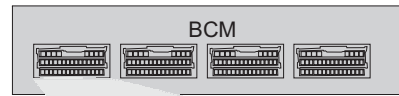

Back view of the module

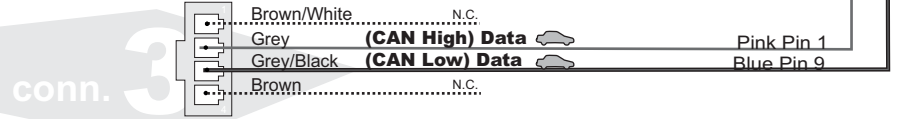

Connect wire to Remote-Starter/Alarm Connect wire to vehicle

○ OUTPUT ● INPUT

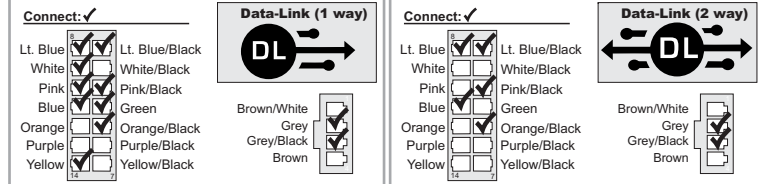

1 **1.A** Make the connections of the CAN-SL-PL to the vehicle:

1.A Connector 1 (Black): Determine the type of installation: INSTALLATION WITH DATA-LINK (SEE P.2) INSTALLATION WITHOUT DATA-LINK (SEE P.2)

1.B Connector 2 (White): Make the connections

1.C Connector 3 (White, located at the back of the module): Make the connections

2 Press the programming switch while inserting the main wires harness (CONN 1) into the CAN-SL-PL module. The LED will illuminate to indicate you are in programming mode, release the programming button.

3 Connect the other connectors (CONN. 2) **WARNING: Connector 2 can be easily plugged in backwards.**

4 Connect the other connectors (CONN. 3)

5 Turn the key to the "ON" position.

6 Once the LED starts to flash rapidly turn the key to the OFF position.

The LED will turn off to indicate the module has been programmed.

The module is now ready for use.



Technical support:
TEL: 514-255-HELP (4357)
FAX: 514-255-1367
Web: www.ifar.ca

Neither the manufacturer or distributor of this module is responsible of damages of any kind indirectly or directly caused by this module, except for the replacement of this module in case of manufacturing defects. This module must be install by qualified technician. This instruction guide may change without notice. Visit www.ifar.ca to get latest version.



SUBARU Forester

2008-2009



CAN-SL-PL and TBSUBARU

Made in Canada Rev. A - 14 / 01 / 2009
Web site: <http://www.ifar.ca>



You must have all keys available. (3 keys)



DEALER SCAN TOOL and associated cartridge is required for programming.

IMPORTANT : The TBSUBARU can only be programmed once. Once the TBSUBARU is programmed, it can't be programmed or used on any other vehicle.

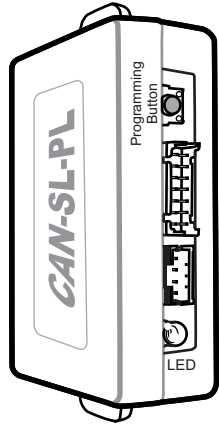

Front view of the module

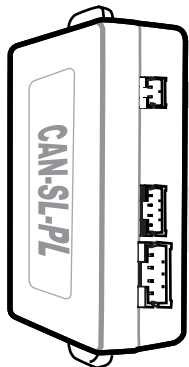
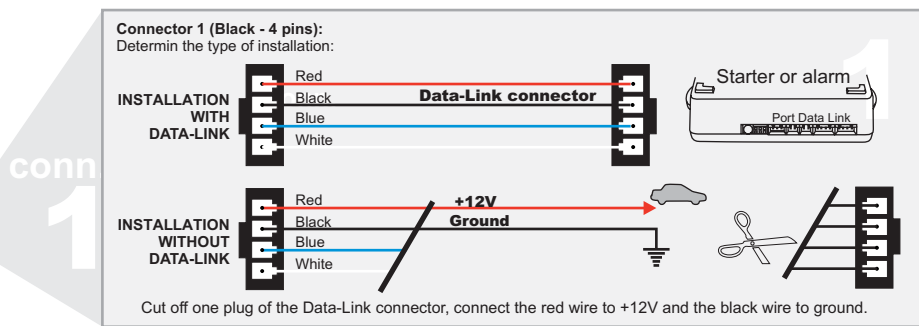

Back view of the module

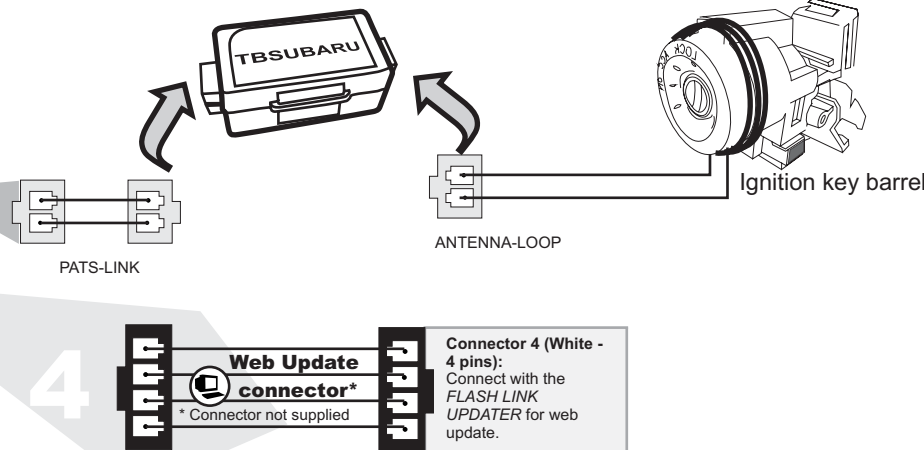

1

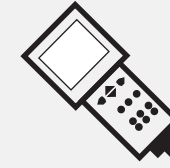

A DEALER SCAN TOOL IS REQUIRED TO PROGRAM THE TBKIA MODULE. A QUALIFIED TECHNICIAN FROM THE DEALERSHIP SHOULD PERFORM STEP 1 AND 4 BELOW.

Hook up the SCAN TOOL
Follow the key programming procedure on the DEALER SCAN TOOL.

2

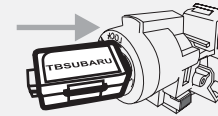

Place the TBSUBARU close to the front of the ignition barrel for the next 2 steps.

3

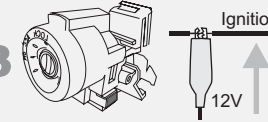

Power up the vehicles ignition using a jumper wire.

4



Follow the instructions on the DEALER SCAN TOOL.

5

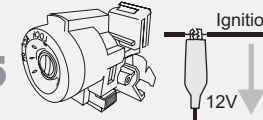

Remove the jumper wire.

6

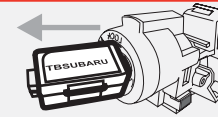

Remove TBSUBARU module.

7



Ensure all of the customers keys are still functional.

8

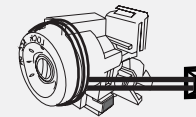

Make 3 to 4 loops around the ignition barrel with the antenna-loop. (Secure the wire with tie-wrap.)

9

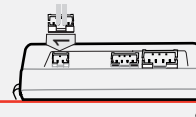

Connect the TBSUBARU module to the CAN-SL-PL using the PATS-LINK cable.

10



Remote start the vehicle.

The module TBSUBARU is now programmed.



Neither the manufacturer or distributor of this module is responsible of damages of any kind indirectly or directly caused by this module, except for the replacement of this module in case of manufacturing defects. This module must be install by qualified technician. This instruction guide may change without notice. Visit www.ifar.ca to get latest version.



SUBARU Forester

2008-2009



CAN-SL-PL et TBSUBARU

Fabriqu  au Canada Rev. A - 14 / 01 / 2009
Site internet <http://www.ifar.ca>

MODULE D'INTERFACE CAN BUS POUR ALARME ET D MARREUR   DISTANCE

Fonctionnel if equipped

<input checked="" type="checkbox"/> Verrouillage	<input checked="" type="checkbox"/> Tach	<input type="checkbox"/> Radio Off	<input type="checkbox"/> Si�ges chauffants
<input checked="" type="checkbox"/> D�verrouillage	<input checked="" type="checkbox"/> Active D�marreur	<input type="checkbox"/> Transponder Bypass	<input type="checkbox"/> Porte essence
<input checked="" type="checkbox"/> Armement	<input checked="" type="checkbox"/> Status de Porte	<input type="checkbox"/> PK3, Passlock	<input type="checkbox"/> Contr�le portes
<input checked="" type="checkbox"/> D�sarmement	<input checked="" type="checkbox"/> Status de Valise	<input checked="" type="checkbox"/> Portes Couillantes	<input type="checkbox"/> Hayon arri�re
<input type="checkbox"/> Valise	<input type="checkbox"/> Status de Capot	<input type="checkbox"/> D�givrage	<input type="checkbox"/> Signal de Frein

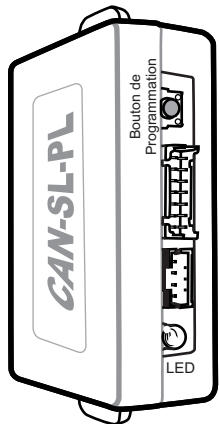

Vue de face du module

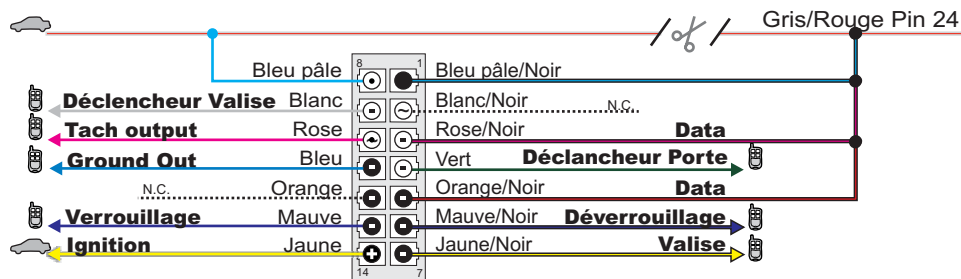

BCM situ s directement sous la colonne de direction .

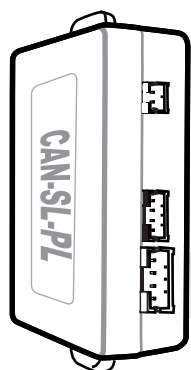
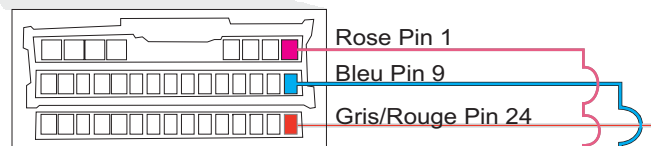
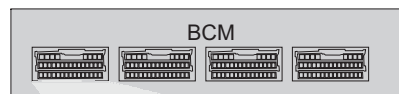

Vue de dos du module

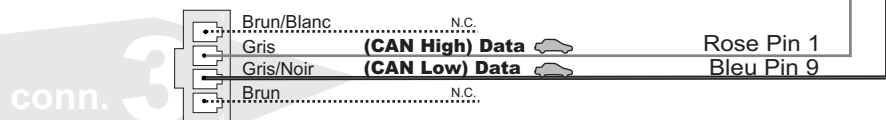

Branchement du filage au d marreur   distance/Alarme Branchement du filage au v hicule ○ SORTIE ● ENTR E

Branchez: ✓	Data-Link (1 way)	Branchez: ✓	Data-Link (2 way)
Bleu p�le <input checked="" type="checkbox"/>		Bleu p�le/Noir <input checked="" type="checkbox"/>	
Blanc <input checked="" type="checkbox"/>		Blanc/Noir <input type="checkbox"/>	
Rose <input checked="" type="checkbox"/>		Rose/Noir <input type="checkbox"/>	
Bleu <input checked="" type="checkbox"/>		Bleu <input checked="" type="checkbox"/>	
Orange <input checked="" type="checkbox"/>		Vert <input type="checkbox"/>	
Mauve <input checked="" type="checkbox"/>		Orange/Noir <input type="checkbox"/>	
Jaune <input checked="" type="checkbox"/>		Mauve/Noir <input type="checkbox"/>	
		Jaune/Noir <input type="checkbox"/>	
		Brun/Blanc <input type="checkbox"/>	
		Gris <input type="checkbox"/>	
		Gris/Noir <input type="checkbox"/>	
		Brun <input type="checkbox"/>	

- 1.1** **Connecteur 1 (Noir):**
D terminez le type d'installation (Data-Link ou non Data-Link) Pour l'installation DATA-LINK assurez vous de la pr sence du connecteur DATA-LINK sur le d marreur. (Voir p.4) Pour installation non Data-Link voir INSTALLATION SANS DATA-LINK. (Voir p.4)
- 1.B** **Connecteur 2 (Blanc):**
Effectuez les branchements
- 1.C** **Connecteur 3 (Blanc, situ  au dos du module):**
Effectuez les branchements
- 2** **Maintenez le bouton de programmation enfonc ** en ins rant le **connecteur 1** dans le CAN-SL-PL. Le DEL s'allume pour indiquer le d but de la programmation, **rel chez le bouton de programmation.**
- 3** Branchez le connecteur 2 (**CONN. 2**)
ATTENTION: Ne pas brancher le connecteur   l'envers.
- 4** Branchez le connecteur 3 (**CONN. 3**)
- 5** Tournez la clef en position **ignition.**
- 6** Lorsque le DEL clignote rapidement, **tournez la clef en position OFF.**
Le DEL s' teint pour indiquer que le module est programm .



Support Technique:
TEL: 514-255-HELP (4357)
FAX: 514-255-1367
Site internet: www.ifar.ca

Ni le manufacturier, ni le distributeur ne se consid rent responsables des dommages caus s ou ayant pu  tre caus s, indirectement ou directement, par ce module, except  le remplacement de ce module en cas de d fectuosit  de fabrication. Ce module doit  tre install  par un technicien qualifi . Ce guide d'instruction peut faire l'objet de changement sans pr avis. Consultez le www.ifar.ca pour voir la plus r cente version.



SUBARU Forester

2008-2009



CAN-SL-PL et TBSUBARU

Fabriqué au Canada Rev. A - 14 / 01 / 2009
Site internet <http://www.ifar.ca>

MODULE D'INTERFACE CAN BUS POUR ALARME ET DÉMARREUR À DISTANCE



Vous devez avoir toutes les clés du véhicule. (3 clés)



Vous avez besoin du SCAN TOOL de SUBARU avec le cartouche approprié pour la programmation des clés.

IMPORTANT : Vous pouvez programmer le TBSUBARU qu'une seule fois.

Une fois le TBSUBARU programmé, il ne peut être reprogrammé ou utilisé sur un autre véhicule.

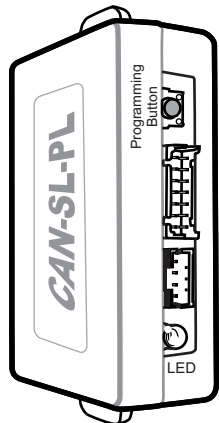

Vue de face du module

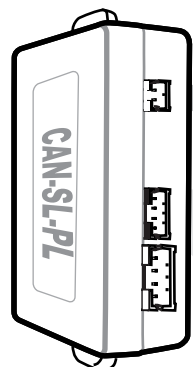
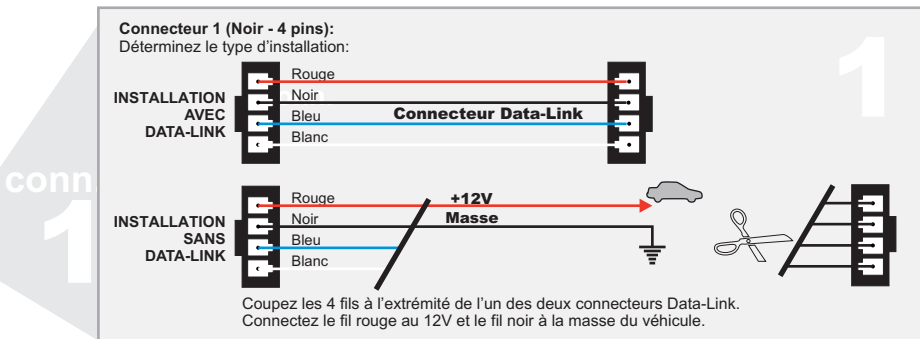

Vue de dos du module

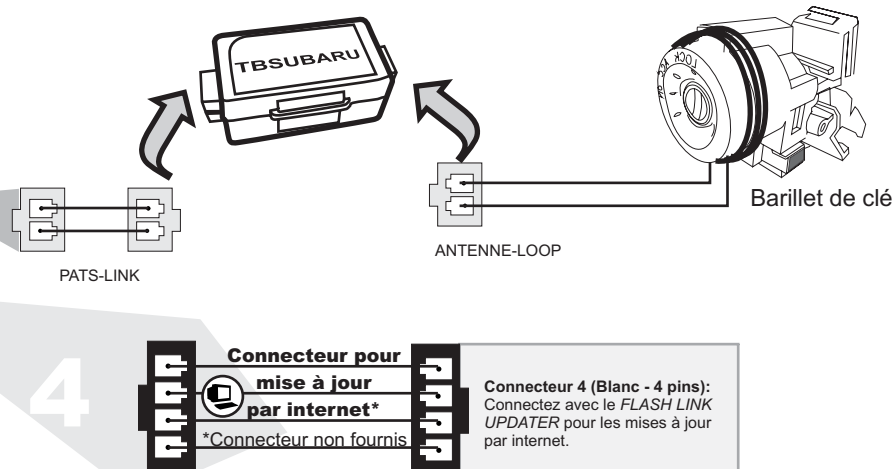

1

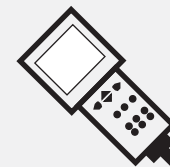

LE SCAN TOOL DU CONCESSIONNAIRE EST REQUIS POUR LA PROGRAMMATION DES CLÉS. UN TECHNICIEN QUALIFIÉ DU CONCESSIONNAIRE DEVAIT EFFECTUER CETTE ÉTAPE ET L'ÉTAPE 4.

Branchez le SCAN TOOL

Suivez les indications du SCAN TOOL pour reprogrammer tous les clés (procédure teaching).

2

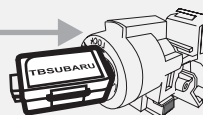

Placez le TBSUBARU devant le barillet d'ignition pour les 2 prochaines étapes.

3

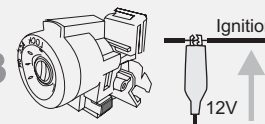

À l'aide d'un fil (jumper), vous devez alimenter l'ignition manuellement

4



Suivez les instructions du DEALER SCAN TOOL.

5

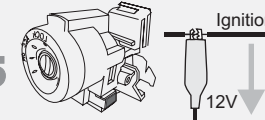

Retirez le fil (jumper).

6

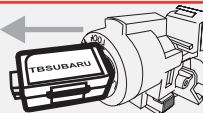

Retirez le module TBSUBARU.

7



Il est important de réessayer chaque clé du véhicule.

8

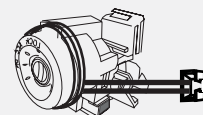

Enroulez les fils de l'antenne autour de barillet d'ignition 3 à 4 tours pour un fonctionnement optimal. (Sécurisez avec une attache de nylon)

9

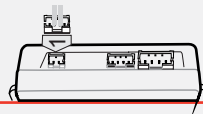

Branchez le module TBSUBARU dans le module CAN-SL-PL avec le câble PATS-LINK.

10

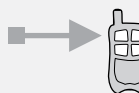

Démarrez la voiture avec le démarreur à distance.

Le module TBSUBARU est maintenant programmé.