

VSS SIGNAL GENERATOR USING CAN PROTOCOLS

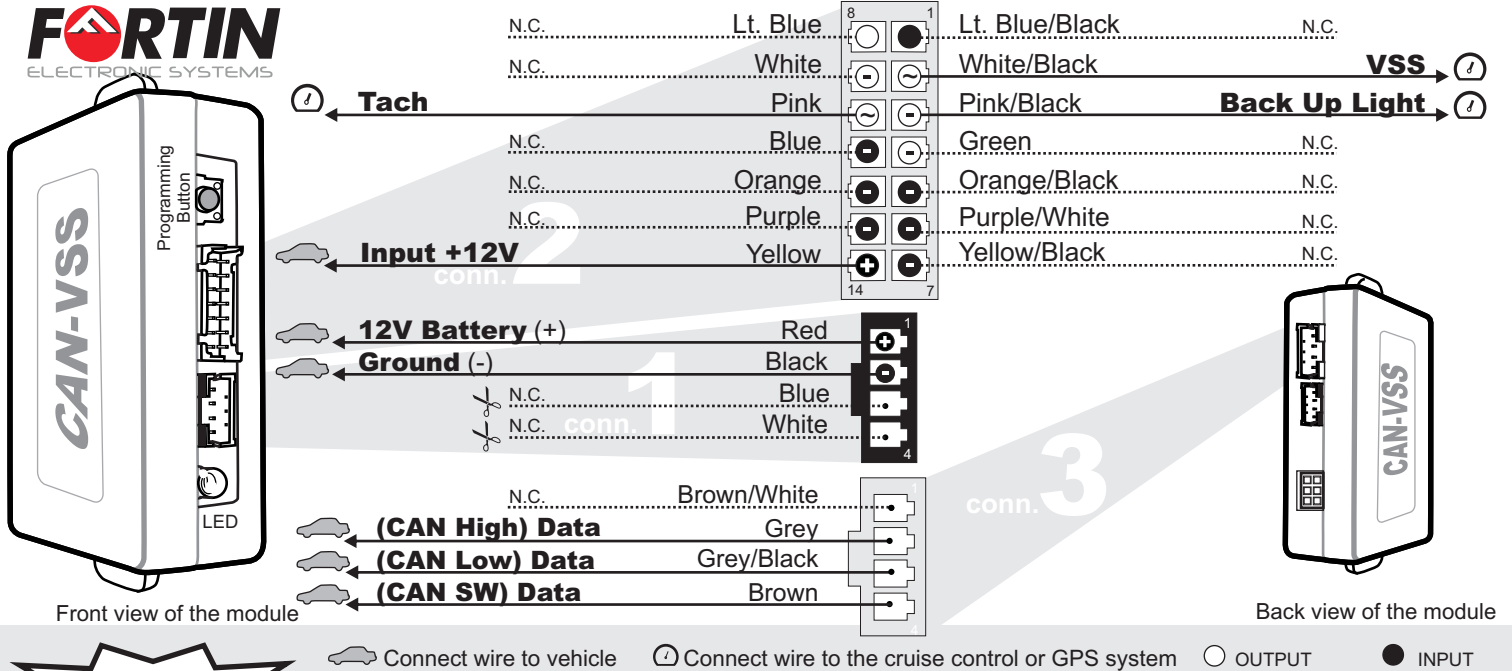

WIRING / CONNECTION GUIDE

See wiring schematic configuration



START HERE

INSTALLATION AND PROGRAMMING INSTRUCTIONS

- 1**
 - 1.A** **Connector 1 (Black):**
Cut off one plug of the Data-Link connector. Connect the red wire to +12V, Connect the black wire to GROUND.
 - 1.B** **Connector 2 (White):**
Make the connections associated with the vehicle in the VEHICLE FIT GUIDE (P.2-3)
 - 1.C** **Connector 3 (White, located at the back of the module):**
Make the connections associated with the vehicle in the VEHICLE FIT GUIDE (P.2-3)
- 2** **Press** the programming switch while inserting the main wires harness (**CONN 1**) into the CAN-VSS module. The LED will illuminate to indicate you are in programming mode, release the programming button.

- 3** **Connect** the other connectors (**CONN. 2**)
- 4** **Connect** the other connectors (**CONN. 3**)
- 5** Turn the key to the **"ON"** position.
- 6** Once the LED starts to flash rapidly turn the key to the **OFF** position. The LED will turn off to indicate the module has been programmed. **The module is now ready for use.**



TECHNICAL SUPPORT / INFORMATION

Neither the manufacturer or distributor of this module is responsible of damages of any kind indirectly or directly caused by this module, except for the replacement of this module in case of manufacturing defects. This module must be install by qualified technician. This instruction guide may change without notice. Visit www.ifar.ca to get latest version.

Soutiens Technique:
TEL: 514-255-HELP (4357)
FAX: 514-255-1367
Web: www.ifar.ca



VEHICLE FIT GUIDE / GUIDE DES VEHICULES

| Vehicles Véhicules | Years Années | VSS | Tech | Back up light Lumière recul | Wiring Schematic Configuration | Vehicle Data Wire Color | Vehicles Véhicules | Years Années | VSS | Tech | Back up light Lumière recul | Wiring Schematic Configuration | Vehicle Data Wire Color |
|-----------------------|----------------------------|-----|------|--------------------------------|-----------------------------------|----------------------------|-----------------------|----------------------------|-----|------|--------------------------------|-----------------------------------|----------------------------|
| | | | | | | | | | | | | | |
| Acura | 02 03 04 05 06 07 08 09 10 | | | | | | Jeep | 02 03 04 05 06 07 08 09 10 | | | | | |
| MDX | | | | | | | Cherokee | | | | | | 8 |
| RL | | | | | | | Commander | | | | | | 8 |
| TL | | | | | | | Compass | | | | | | 8 |
| TSX | | | | | | | Grand Cherokee | | | | | | 8 |
| Audi | 02 03 04 05 06 07 08 09 10 | | | | | | Patriot | | | | | | 8 |
| A3 | | | | | | | Liberty | | | | | | 8 |
| A4 | | | | | | | Wrangler | | | | | | 8 |
| A8 | | | | | | | Lincoln | 02 03 04 05 06 07 08 09 10 | | | | | |
| S4 | | | | | | | MKZ | | | | | | 12 |
| TT | | | | | | | Mazda | 02 03 04 05 06 07 08 09 10 | | | | | |
| BMW | 02 03 04 05 06 07 08 09 10 | | | | | | Mazda3 | | | | | | 7 |
| 3 Series | | | | | | | Mazda 5 | | | | | | 7 |
| 5 Series | | | | | | | Mazda 6 | | | | | | 7 |
| X5 | | | | | | | MX-5 | | | | | | 7 |
| Buick | 02 03 04 05 06 07 08 09 10 | | | | | | Mercedes | 02 03 04 05 06 07 08 09 10 | | | | | |
| Enclave | | | | | | | C230 | | | | | | 8 |
| Lucerne | | | | | | | C32 | | | | | | 8 |
| Cadillac | 02 03 04 05 06 07 08 09 10 | | | | | | SLK 280 | | | | | | 8 |
| CTS | | | | | | | Mini | 02 03 04 05 06 07 08 09 10 | | | | | |
| DTS | | | | | | | Cooper | | | | | | 1 |
| Escalade | | | | | | | | | | | | | 1 |
| SRX | | | | | | | Mitsubishi | 02 03 04 05 06 07 08 09 10 | | | | | |
| Chevrolet | 02 03 04 05 06 07 08 09 10 | | | | | | Outlander | | | | | | 13 |
| Avalanche | | | | | | | Lancer | | | | | | 13 |
| CK Pickup | | | | | | | Nissan | 02 03 04 05 06 07 08 09 10 | | | | | |
| Cobalt | | | | | | | Altima | | | | | | 7 |
| Equinox | | | | | | | Frontier | | | | | | 7 |
| Express | | | | | | | Maxima | | | | | | 7 |
| HHR | | | | | | | Maxima IK* | | | | | | 7 |
| Impala | | | | | | | Murano | | | | | | 7 |
| Malibu | | | | | | | Murano IK* | | | | | | 7 |
| Monte Carlo | | | | | | | Pathfinder | | | | | | 7 |
| Silverado | | | | | | | Quest | | | | | | 7 |
| Suburban | | | | | | | Rogue | | | | | | 7 |
| Tahoe | | | | | | | Sentra | | | | | | 7 |
| Chrysler | 02 03 04 05 06 07 08 09 10 | | | | | | Titan | | | | | | 7 |
| Aspen | | | | | | | Versa | | | | | | 7 |
| Sebring | | | | | | | Xterra | | | | | | 7 |
| Town and Country | | | | | | | 350Z | | | | | | 7 |
| 300 | | | | | | | Pontiac | 02 03 04 05 06 07 08 09 10 | | | | | |
| 300C | | | | | | | Pursuit | | | | | | 9 |
| Dodge | 02 03 04 05 06 07 08 09 10 | | | | | | G5 | | | | | | 9 |
| Avenger | | | | | | | G6 | | | | | | 9 |
| Caliber | | | | | | | Solstice | | | | | | 9 |
| Caravan | | | | | | | Torrent | | | | | | 9 |
| Charger | | | | | | | Porsche | 02 03 04 05 06 07 08 09 10 | | | | | |
| Dakota | | | | | | | Cayenne | | | | | | 1 |
| Durango | | | | | | | Saturn | 02 03 04 05 06 07 08 09 10 | | | | | |
| Magnum | | | | | | | Aura | | | | | | 9 |
| Nitro | | | | | | | Outlook | | | | | | 9 |
| Ram | | | | | | | Sky | | | | | | 9 |
| Sprinter | | | | | | | Vue | | | | | | 9 |
| Ford | 02 03 04 05 06 07 08 09 10 | | | | | | Smart | 02 03 04 05 06 07 08 09 10 | | | | | |
| Edge | | | | | | | Fortwo | | | | | | 7 |
| Escape | | | | | | | Subaru | 02 03 04 05 06 07 08 09 10 | | | | | |
| Escape (hybrid) | | | | | | | Impreza | | | | | | 14 |
| Five Hundred | | | | | | | Suzuki | 02 03 04 05 06 07 08 09 10 | | | | | |
| Freestyle | | | | | | | XL7 | | | | | | 9 |
| Mustang | | | | | | | Toyota | 02 03 04 05 06 07 08 09 10 | | | | | |
| GMC | 02 03 04 05 06 07 08 09 10 | | | | | | Prius | | | | | | 3 |
| Acadia | | | | | | | Volkswagen | 02 03 04 05 06 07 08 09 10 | | | | | |
| Savana | | | | | | | Beetle | | | | | | 1 |
| Sierra | | | | | | | Golf | | | | | | 1 |
| Suburban | | | | | | | Eos | | | | | | 2 |
| Yukon | | | | | | | Jetta | | | | | | 2 |
| Honda | 02 03 04 05 06 07 08 09 10 | | | | | | Passat | | | | | | 1 |
| Accord | | | | | | | Rabbit | | | | | | 2 |
| Accord Hybrid | | | | | | | Touareg | | | | | | 1 |
| Civic | | | | | | | Volvo | 02 03 04 05 06 07 08 09 10 | | | | | |
| Fit | | | | | | | C30 | | | | | | 5 |
| Odyssey | | | | | | | C70 | | | | | | 5 |
| Ridgeline | | | | | | | S40 | | | | | | 5 |
| Hummer | 02 03 04 05 06 07 08 09 10 | | | | | | V50 | | | | | | 5 |
| H2 | | | | | | | Infiniti | 02 03 04 05 06 07 08 09 10 | | | | | |
| Hyundai | 02 03 04 05 06 07 08 09 10 | | | | | | FX35, FX45 | | | | | | 7 |
| Azera | | | | | | | FX35, FX45 I.K.* | | | | | | 7 |
| Veracruz | | | | | | | G35 | | | | | | 7 |
| Infiniti | 02 03 04 05 06 07 08 09 10 | | | | | | G35 Intel. Key | | | | | | 7 |
| FX35, FX45 | | | | | | | G37 | | | | | | 7 |
| FX35, FX45 I.K.* | | | | | | | M35, M45 | | | | | | 7 |
| G35 | | | | | | | Q45 | | | | | | 7 |
| G35 Intel. Key | | | | | | | QX56 | | | | | | 7 |

Black: Noir
Blue: Bleu
Brown: Brun
Green: Vert
Gray: Gris
Lt: Pâle
Orange: Orange
Pink: Rose
Purple: Mauve
Red: Rouge
Tan: Beige
Yellow: Jaune
White: Blanc

* :IK = Intelli-Key

This Vehicle Fit Guide may change without notice. Visit www.ifar.ca to get latest version.
Ce Guide des véhicules peut faire l'objet de changement sans préavis.
Consultez le www.ifar.ca pour voir la plus récente version.



VEHICLE FIT GUIDE / GUIDE DES VÉHICULES

Configuration 1

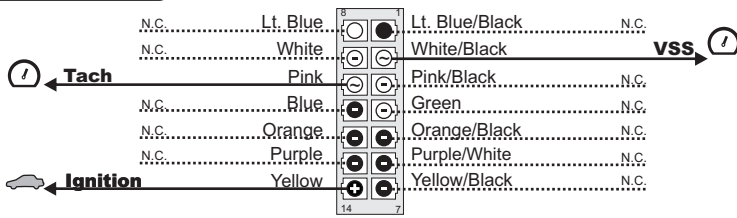

Twisted Pair Wires in driver kick panel (See wires colors VEHICULE FIT GUIDE P.2)
Paire de fils torsadés situés dans le panneau latéral du côté chauffeur (Voir le GUIDE DES VÉHICULES, pour la couleur des fils. P.2)

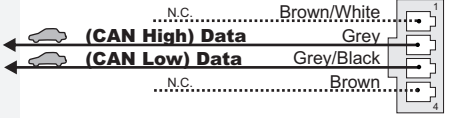

Configuration 2

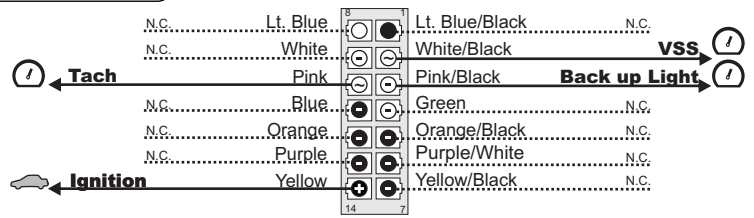

Twisted Pair Wires in driver kick panel (See wires colors VEHICULE FIT GUIDE P.2)
Paire de fils torsadés situés dans le panneau latéral du côté chauffeur (Voir le GUIDE DES VÉHICULES, pour la couleur des fils. P.2)

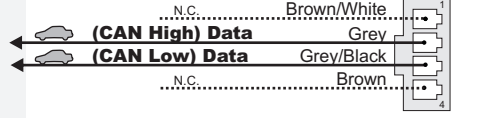

Configuration 3

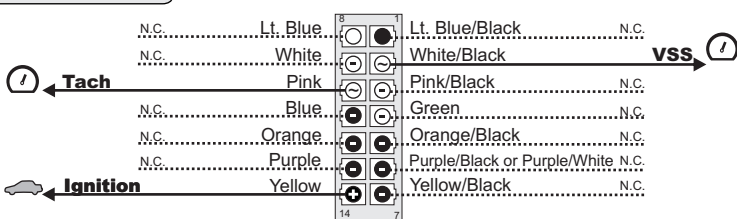

Not twisted Pair Wires located in driver kick panel. (See colors wires on the VEHICULE FIT GUIDE p.2). *Paire de fils pas torsadés situés dans le panneau latéral du côté chauffeur. (Voir la couleur des fils dans le GUIDE DES VÉHICULES p.2)*

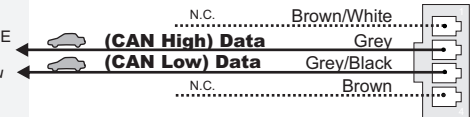

Configuration 4

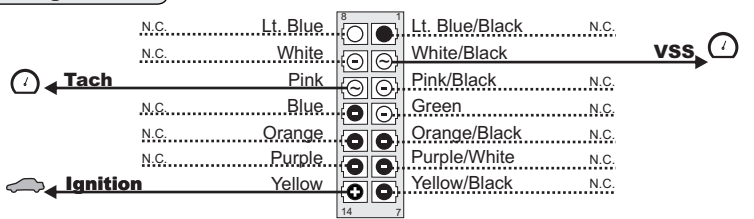

Twisted Pair Wires located under the glove compartment at the BCM. (See colors wires on the VEHICULE FIT GUIDE p.2)
Paire de fils torsadés situés sous le coffre à gant au BCM. (Voir la couleur des fils dans le GUIDE DES VÉHICULES p.2)

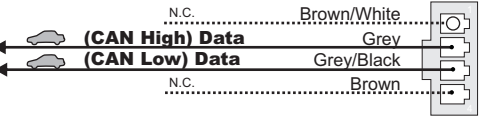

Configuration 5

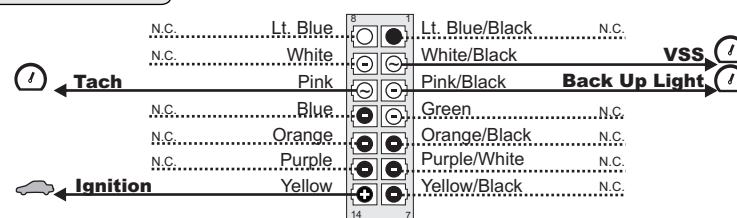

2004 - : Twisted Pair Wires located in the driver kick panel (See colors wires on the VEHICULE FIT GUIDE p.2)
Paire de fils torsadés situés dans le panneau latéral du côté chauffeur. (Voir la couleur des fils dans le GUIDE DES VÉHICULES p.2)

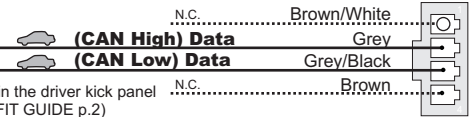

Configuration 6

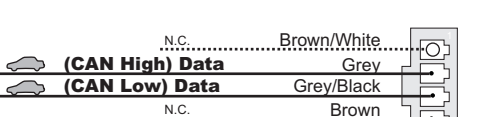
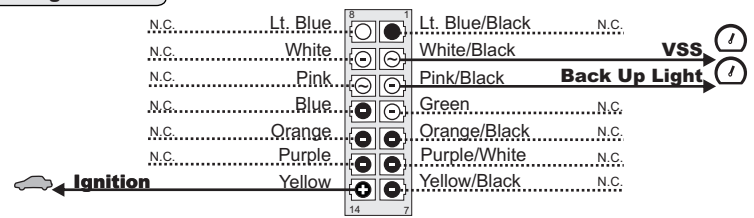

Configuration 7

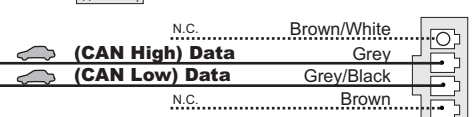
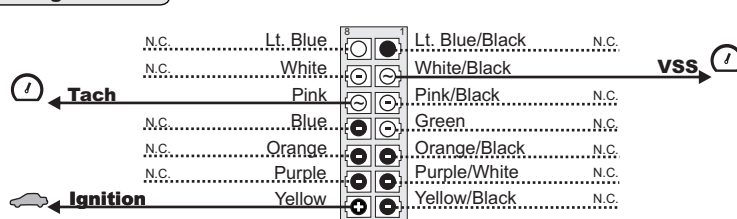

Configuration 8

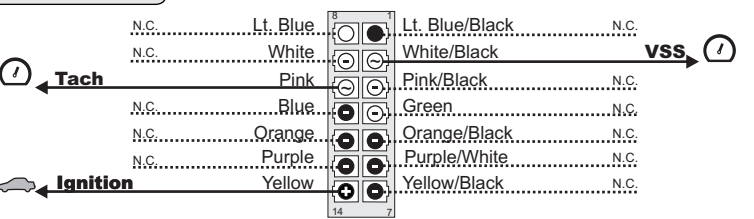

Twisted Pair Wires located at steering wheel column. (See colors wires on the VEHICULE FIT GUIDE p.2). *Paire de fils torsadés situés à la colonne de direction. (Voir la couleur des fils dans le GUIDE DES VÉHICULES p.2)*

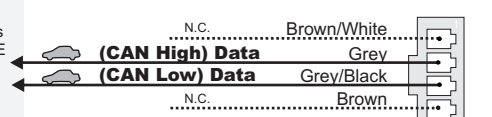

WIRING SCHEMATIC CONFIGURATION / SCHÉMA DE BRANCHEMENT

Configuration 9

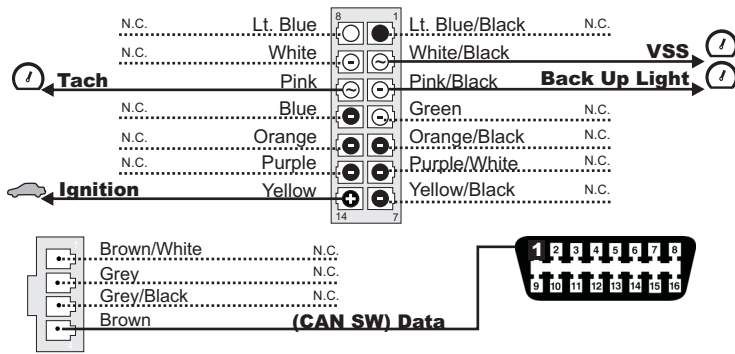

Configuration 11

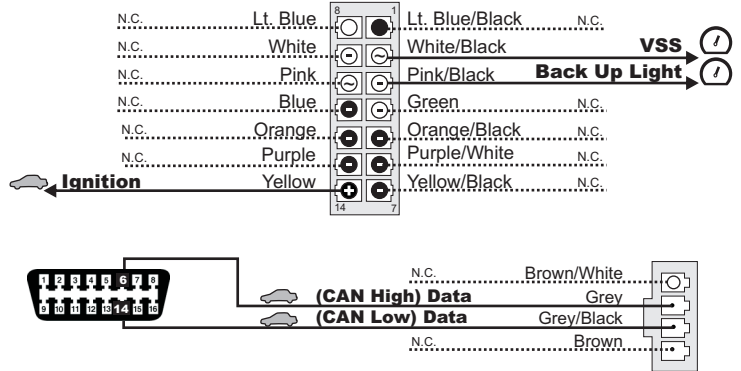

Configuration 12

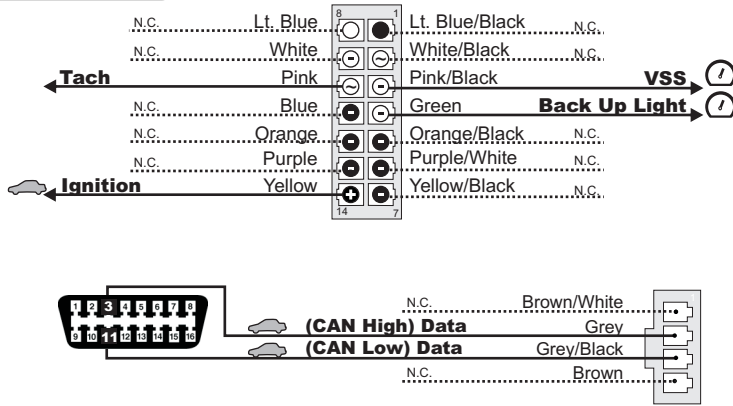

Configuration 13

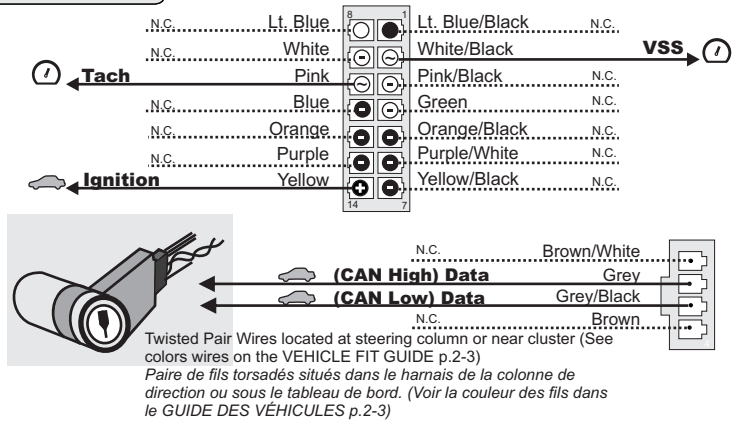

Configuration 14

BCM located directly below the steering column.
 BCM situés directement sous la colonne de direction.

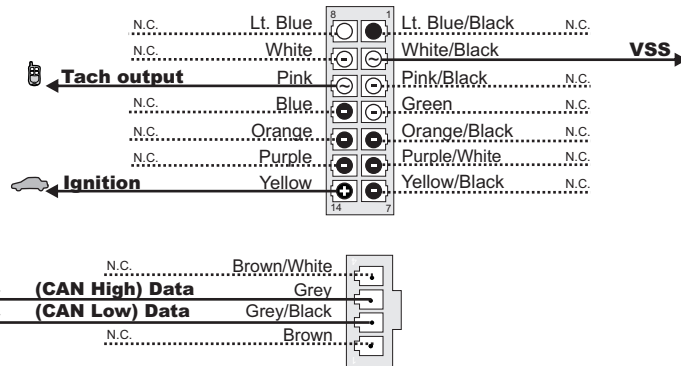
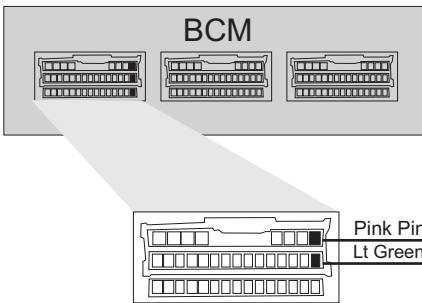

GÉNÉRATEUR DE SIGNAL VSS SUR PROTOCOLE CAN



CÂBLAGE / GUIDE DE CONNEXION

Voir SCHÉMA DE BRANCHEMENT

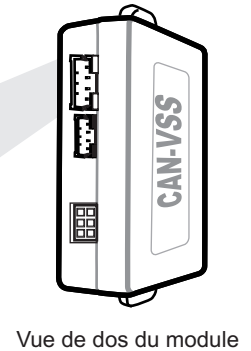
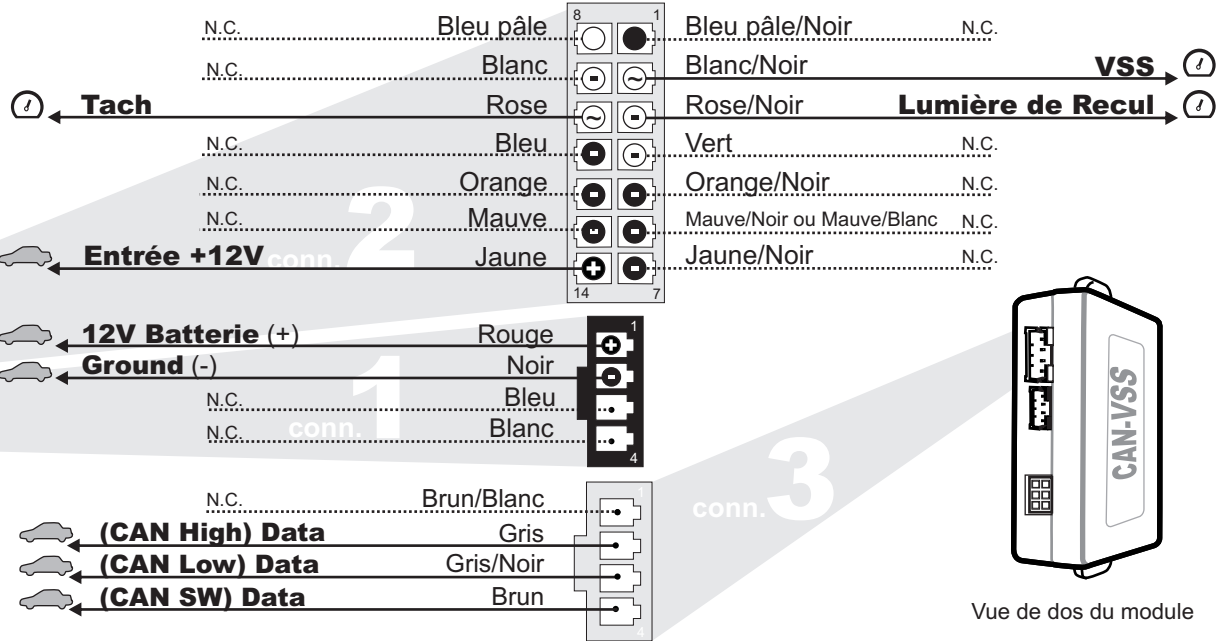
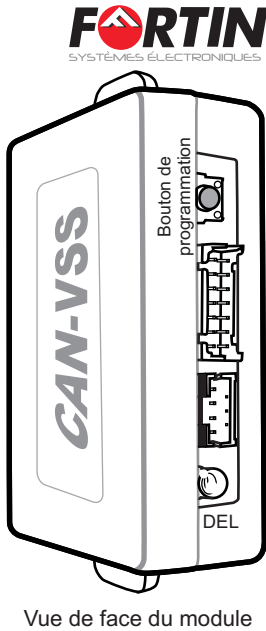

Branchement du filage au véhicule
 Branchement du filage au régulateur de vitesse ou au GPS
 SORTIE
 ENTRÉE

COMMENCEZ ICI

INSTRUCTIONS D'INSTALLATION ET DE PROGRAMMATION

- 1** **1.A** **Connecteur 1 (Noir):**
Coupez les 4 fils à l'extrémité de l'un des deux connecteurs Data-Link.
Connectez le fil rouge au +12V,
Connectez le fil noir à la masse du véhicule.

1.B **Connecteur 2 (Blanc):**
Déterminez le type de branchement selon votre véhicule
(Voir GUIDE DES VOITURES, P.2)

1.C **Connecteur 3 (Blanc, situé au dos du module):**
Déterminez le type de branchement selon votre véhicule
(Voir GUIDE DES VOITURES, P.2)

2 **Maintenez le bouton de programmation enfoncé** en insérant le **connecteur 1** dans le CAN-VSS.
Le DEL s'allume pour indiquer le début de la programmation, **relâchez le bouton de programmation.**

- 3** Branchez le connecteur 2 (**CONN. 2 (blanc)**) situé en avant du module)
- 4** Branchez le connecteur 3 (**CONN. 3, blanc**) situé à l'arrière du module)
- 5** Tournez la clef en position **ignition.**
- 6** Lorsque le DEL clignote rapidement, **tournez la clef en position OFF.** Le DEL s'éteint pour indiquer que le module est programmé.

TECHNICAL SUPPORT / INFORMATION

Ni le fabricant, ni le distributeur ne se considèrent responsables des dommages causés ou ayant pu être causés, indirectement ou directement, par ce module, excepté le remplacement de ce module en cas de défectuosité de fabrication. Ce module doit être installé par un technicien qualifié. Ce guide d'instruction peut faire l'objet de changement sans préavis. Consultez le www.ifar.ca pour voir la plus récente version.

Soutiens Technique:
TEL: 514-255-HELP (4357)
FAX: 514-255-1367
Web: www.ifar.ca

