

# EVO-CAN

Guide # 3471

**SUZUKI**

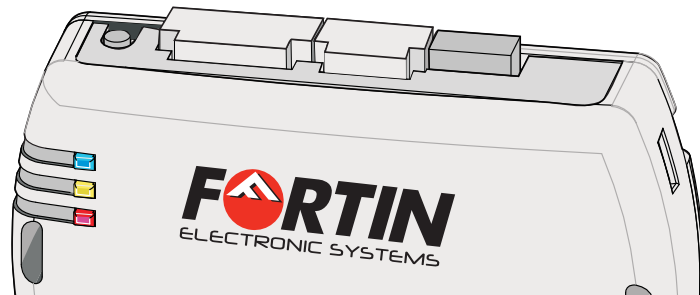

	<b>HARDWARE VERSION</b> <b>VERSION DU MATÉRIEL</b>	<b>FIRMWARE VERSION</b> <b>VERSION DU LOGICIEL</b>
	Minimum <b>3</b>	Minimum <b>4.0</b>



Module label | Étiquette sur le module

**Notice:** Updated Firmware and Installation Guides

**Updated firmware and installation guides** are posted on our web site on a regular basis. We recommend that you update this module to the latest firmware and download the latest installation guide(s) prior to the installation of this product.

**Des mises à jour du Firmware (microprogramme) et des guides d'installation** sont mises en ligne régulièrement. Vérifiez que vous avez bien la dernière version logiciel et le dernier guide d'installation avant l'installation de ce produit.



**TECH SUPPORT**  
Tél: 514-255-HELP (4357)  
1-877-336-7797



**ADDENDUM GUIDE**  
Rev : 20111027

**www.fortinbypass.com**  
WEB UPDATE | MISE À JOUR INTERNET



# WIRE LEGEND | LEGENDE

Input | *Entrée*    Output | *Sortie*

Connection always **required**  
*Branchement toujours requis*

Connection **not required** with Data-link  
*Branchement **non requis** avec Data-Link*

Connect to vehicle  
*Branchement au véhicule*

Connect to Remote-Starter/Alarm  
*Branchement au démarreur à distance/Alarme*

**NOTE:**

All possible functions are summarized in each configuration, however some functions may not be supported on all vehicles. Refer to the VEHICLE FIT GUIDE to determine the supported functions for a specific vehicle.  
Toutes les fonctions possibles sont écrites dans chaque configuration, toutefois elles ne sont pas toutes supportées par tous les véhicules. Voir le GUIDE DES VÉHICULES pour déterminer les fonctions supportées sur chaque véhicule.

## DESCRIPTION

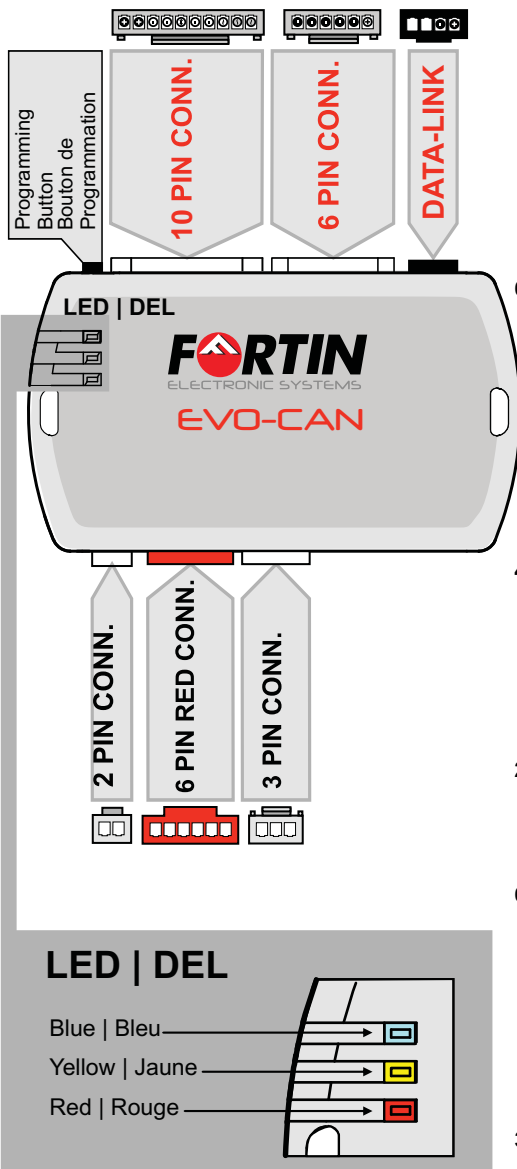

**10 PIN CONNECTOR: MAIN HARNESS | HARNAIS PRINCIPAL (WHITE|BLANC)**

Yellow   Jaune	Ignition
Red/Blue   Rouge/Bleu	Start
Green   Vert	Door Status   Statuts Portes
White   Blanc	Trunk Status   Statuts Valise
White/Black   Blanc/Noir	AUX2 / KEY SENSE
Brown/White   Brun/Blanc	Hand Brake Status   Frein à Main Signal
Pink/Black   Rose/Noir	Hood Status   Capot Statuts
Pink   Rose	Tachometer
Lt. Blue/Black   Bleu Pâle/Noir	DATA 1 See configuration
Lt. Blue   Bleu Pâle	DATA 2 See configuration

**6 PIN CONNECTOR: MAIN HARNESS | HARNAIS PRINCIPAL (WHITE|BLANC)**

Orange/Black   Orange/Noir	Foot Brake Status   Statuts Frein (pied)
Orange	AUX 1
Purple/White   Mauve/Blanc	Unlock/Disarm   Déverrouille/Désarme
Purple   Mauve	Lock/Arm   Verrouille/Arme
Yellow/Black   Jaune/Noir	Trunk Release   Valise
Dk. Blue   Bleu foncé	GWR (Ground While Running)

**4 PIN CONNECTOR: DATA-LINK (BLACK | NOIR) SEE PAGE 3 | VOIR PAGE 3**

Red   Rouge	(+) 12V Battery   (+) 12V Batterie
Black   Noir	Ground (-)   Masse (-)
Blue   Bleu	DATA
White   Blanc	DATA

**2 PIN CONNECTOR: TB CONTROL (WHITE | BLANC)**

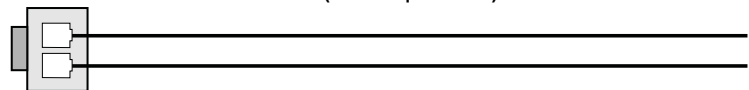

**6 PIN CONNECTOR: RELAY | RELAIS (RED | ROUGE)**

White/Red   Blanc/Rouge	COMM2
White/Blue   Blanc/Bleu	NO2
White/Green   Blanc/Vert	NC2
Yellow/Red   Jaune/Rouge	COMM1
Yellow/Blue   Jaune/Bleu	NO1
Yellow/Green   Jaune/Vert	NC1

**3 PIN CONNECTOR: CAN-BUS (WHITE | BLANC)**

Brown   Brun	CAN 1 WIRE (SW)
Gray/Black   Gris/Noir	CAN LOW
Gray   Gris	CAN HIGH

**LED | DEL**

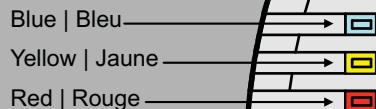

# INSTALLATION PROCEDURE

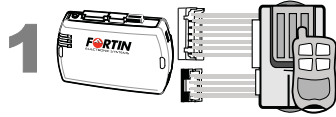

**Determine if the remote-starter or alarm system supports 2-way Data-Link.**

**Déterminez si le démarreur à distance ou système d'alarme est compatible en Data-Link 2-voies.**

## WITH DATA-LINK AVEC DATA-LINK

In order to utilize this type of connection the remote-starter or alarm-system must be compatible with the **Fortin Data-link protocol**. Consult the installation guide or visit [www.fortinbypass.com/datalink/](http://www.fortinbypass.com/datalink/) for more information.

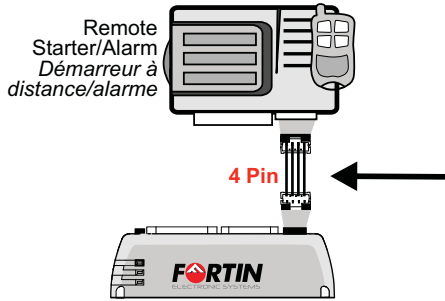

Le démarreur à distance ou le système d'alarme doit être compatible avec le **protocole Data-link Fortin** pour ces branchements. Consultez le guide d'installation du démarreur à distance ou du système d'alarme ou visitez le [www.fortinbypass.com/datalink/](http://www.fortinbypass.com/datalink/) pour plus d'informations.

## WITH OUT DATA-LINK SANS DATA-LINK

For all other remote-starters or alarm-systems perform the following connections.

Pour tout autres types de démarreurs à distance ou d'alarme, effectuez les branchements suivants.

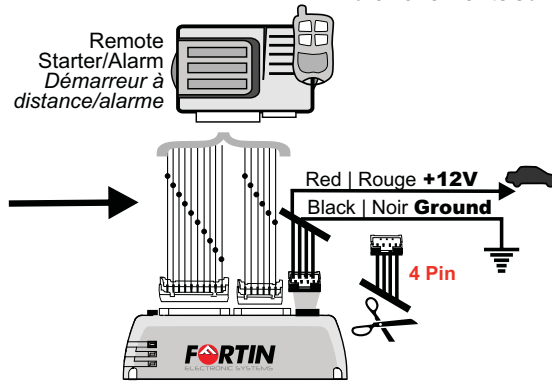

- 1 Cut off one plug of the 4 Pin Data-Link connector
- 2 Connect the Red wire to +12V
- 3 Connect the Black wire to Ground

- 1 Coupez l'extrémité du connecteur 4 pins Data-Link
- 2 Connectez le fil rouge au 12V
- 3 Connectez le fil noir à la masse du véhicule.

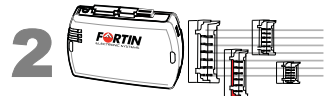

**Make the connections:**

**Faire les branchements:**



**10 Pin Connector (White):**  
Make the connections associated with the vehicle from the VEHICLE FIT GUIDE.

**10 Pins Connecteur (Blanc):**  
Effectuez les branchements associés au véhicule dans le GUIDE DES VÉHICULES.



**6 Pin Connector (White):**  
Make the connections (if required)

**6 Pins Connecteur (Blanc):**  
Effectuez les branchements.(Si nécessaire)



**3 Pin Connector CAN (White):**  
Make the connections (if required)

**3 Pins Connecteur CAN (Blanc):**  
Effectuez les branchements.(Si nécessaire)



**6 Pin Connector RELAY (Red):**  
Make the connections (if required)

**6 Pins Connecteur RELAI (Rouge):**  
Effectuez les branchements.(Si nécessaire)



**2 Pin Connector (White):**  
Make the connections (if required)

**2 Pins Connecteur (Blanc):**  
Effectuez les branchements.(Si nécessaire)



## PROGRAMMING PROCEDURE

## PROCÉDURE DE PROGRAMMATION

Determine the programming procedure required for the vehicle in the VEHICLE FIT GUIDE.

Déterminez le type de programmation selon votre véhicule dans le GUIDE DES VÉHICULES.

Connection number  
Numéro de connexion

Vehicle(s) associated with the procedure  
Véhicule(s) associé(s) à la configuration

Programming number  
Numéro de programmation

**CONNECTION #**

**VEHICLE MAKE MODEL YEAR**

**PROGRAM: #**

## VEHICLES FIT GUIDE | GUIDE DES VÉHICULES

VEHICLES   VEHICULES	YEARS ANNÉES	Connection	Programming	Functional if equipped   Fonctionnelle si le véhicule en est équipé.																										See Legend Below	
				Lock	Unlock	Arm	Disarm	Hatch (open)	Trunk (open)	Sliding Door	Window Roll Down	Gas Door	RAP Disable	Parking Light	Memory Driver	Tachometer	Heated Seats	Heated Mirrors	Rear Defrost	Door Status	Trunk Status	Hood Status	Hand-Brake Status	Foot-Brake Status	Transponder Bypass	PK3, Passlock	Key Control	Activate OEM Remote Start	Push-to-Start Control	Legend	
				A	B	C	D	E	F	G	H	I	J	K	L	M	O	P	Q	R	S	T	U	V	W	X	Y	Z	ZA	ZB	
<b>SUZUKI</b>																															
Equator	2009-2011	1	3	•	•										•					•		•	•	•	•						10
Grand Vitara	2009-2011	2	3	•	•	•	•		•						•					•	•		•	•	•						10
Swift	2005-2006 2008	3	1																						•						
Verona	2004-2006	4	1																				•	•	•						
SX4	2008-2011	2	3			•	•		•						•					•	•				•						10
XL7	2007-2009	5	2	•	•	•	•		•					•						•	•	•	•	•	•		•		•		1

## LEGEND | LÉGENDE

**1 - TB-GM2\*** for transponder bypass pour contournement du transpondeur  
**2 - TB-KIA1\*** for transponder bypass pour contournement du transpondeur  
**3 - TB-KIA2\*** for transponder bypass pour contournement du transpondeur  
**4 - TB-MITS2\*** for transponder bypass pour contournement du transpondeur  
**5 - Heated seats will only turn ON (low power) if the engine temperature is below 0°C (32°F) when remote started.**  
 Les sièges chauffants s'allument à faible intensité SEULEMENT si la température du moteur est sous 0°C

**6 - INT-BMW1\*** for remote car starter | Pour démarreur à distance  
**7 - TB-SUBARU1 or 2\*** for transponder bypass | pour contournement du transpondeur  
**8 - A special diagram is required for Remote car starter : www.fortinbypass.com**  
 Un diagramme spécial est requis pour démarreur à distance : www.fortinbypass.com  
**9 - INSET\*** for remote car starter | Pour démarreur à distance  
**10 - EVO-CAN version hardware 3+ required | version du matériel: 3+ requis**

\* Sold separately | Vendu séparément

**Key Control :** (Contrôle de la Clé) KEY REQUIRED. Transponder bypass by wrapping of factory key. CLÉ REQUISE. The EVO-CAN activates the relay on connector 2 (White wire) during remote start. Contournement du transpondeur par enroulement de la clé d'origine. Le EVO-CAN active le relais du connecteur 2 pin Blanc lors du démarrage à distance.

**Activate OEM Remote Start :** (Active Démarreur d'orgine) The EVO-CAN activates the factory remote starter if the vehicle has one equipped. Le EVO-CAN active le démarreur à distance d'origine lorsque le véhicule en est équipé.

**Push-to-Start Control :** (Contrôl Bouton Démarreur) For Push-to-Start vehicles, the EVO-CAN activates the push button to allow seamless takeover by the user. Pour les véhicules équipés de bouton Push-to-Start, le EVO-CAN actionne le bouton dans le but d'éviter à l'utilisateur de le faire avant de conduire le véhicule.



Connection always **required**  
Branchement toujours **requis**

Connection **not required** with Data-link  
Branchement **non requis** avec Data-Link



Connect to vehicle  
Branchement au véhicule



Connect to Remote-Starter/Alarm  
Branchement au démarreur à distance/Alarme

**CONNECTION 1**

**SUZUKI EQUATOR**

**GO PROGRAM: 3**

	HARDWARE VERSION VERSION DU MATERIEL	FIRMWARE VERSION VERSION DU LOGICIEL
	Minimum <b>3</b>	Minimum <b>4.0</b>

**Transponder connector**  
White connector - Back view  
**Connecteur du transpondeur**  
Conecteur Blanc - Vue de dos

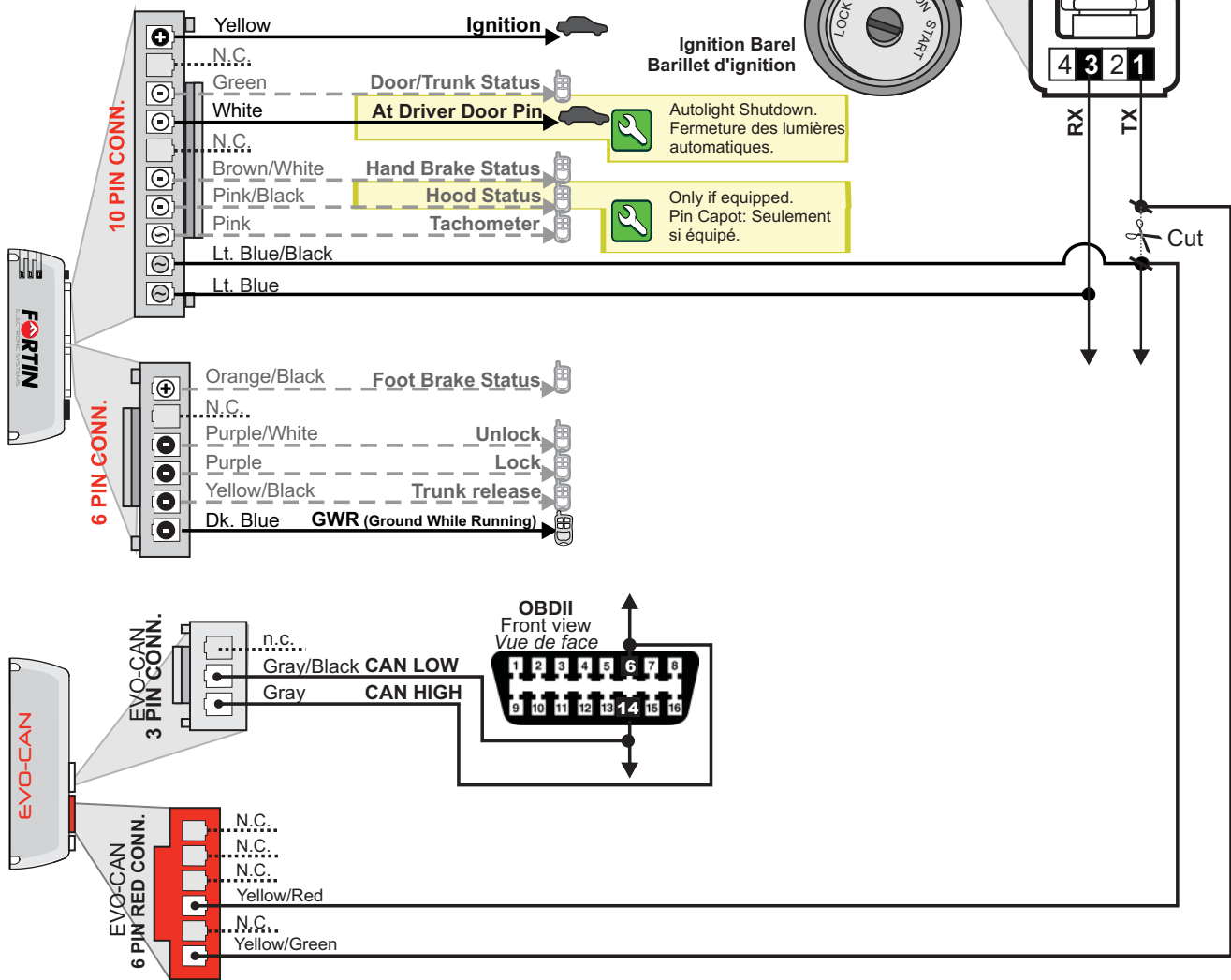

**CONNECTION 2**

**SUZUKI GRAND VITARA / SX4**

**GO PROGRAM: 3**

	HARDWARE VERSION VERSION DU MATÉRIEL	FIRMWARE VERSION VERSION DU LOGICIEL
	Minimum <b>3</b>	Minimum <b>4.0</b>

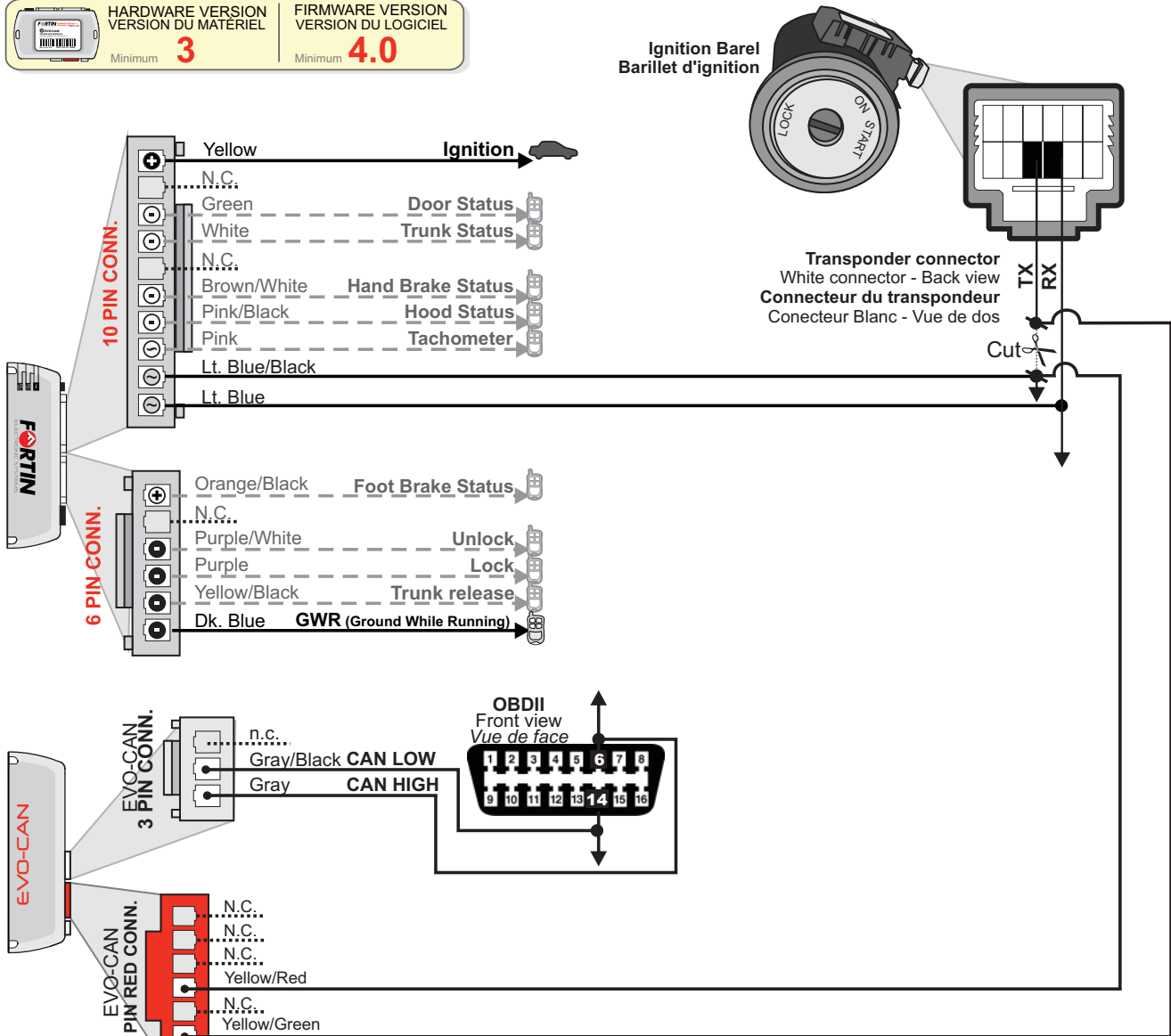

**SUZUKI SX4**

**BCM connector: Driver side dash**  
Connecteur BCM: sous le tableau de bord côté conducteur.

**Back view**  
Vue de dos

**(-) LOCK**  
Gray/White  
Gris/Blanc

**(-) UNLOCK**  
Gray/Red  
Gris/Rouge

**REMOTE STARTER**  
DÉMARREUR À DISTANCE

**Vehicle equipped with INTELLI-KEY**  
Véhicule équipé d'une clé INTELLI-KEY

**Remove the valet key from the back of the OEM remote.**  
Retirez la clé valet du dos de la télécommande d'origine.

**Keep the OEM remote at least 3 meters (10 feet) away from the vehicle to proceed.**  
Éloignez la télécommande d'origine du véhicule (10 pieds / 3 mètres min) pour procéder à la programmation.

**CONNECTION 3**

**SUZUKI SWIFT**

**GO PROGRAM: 1**

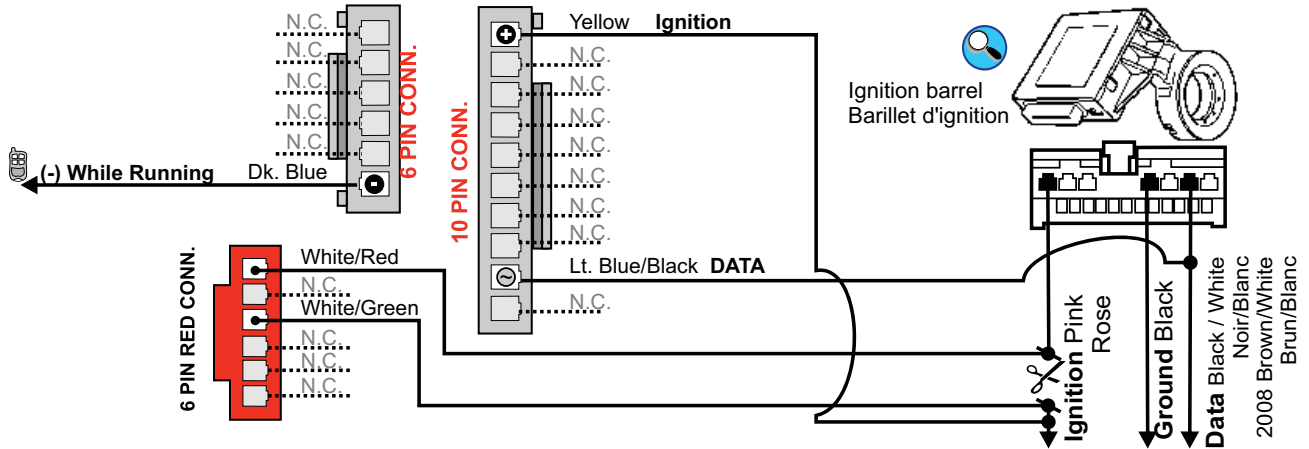

**CONNECTION 4**

**SUZUKI VERONA**

**GO PROGRAM: 1**

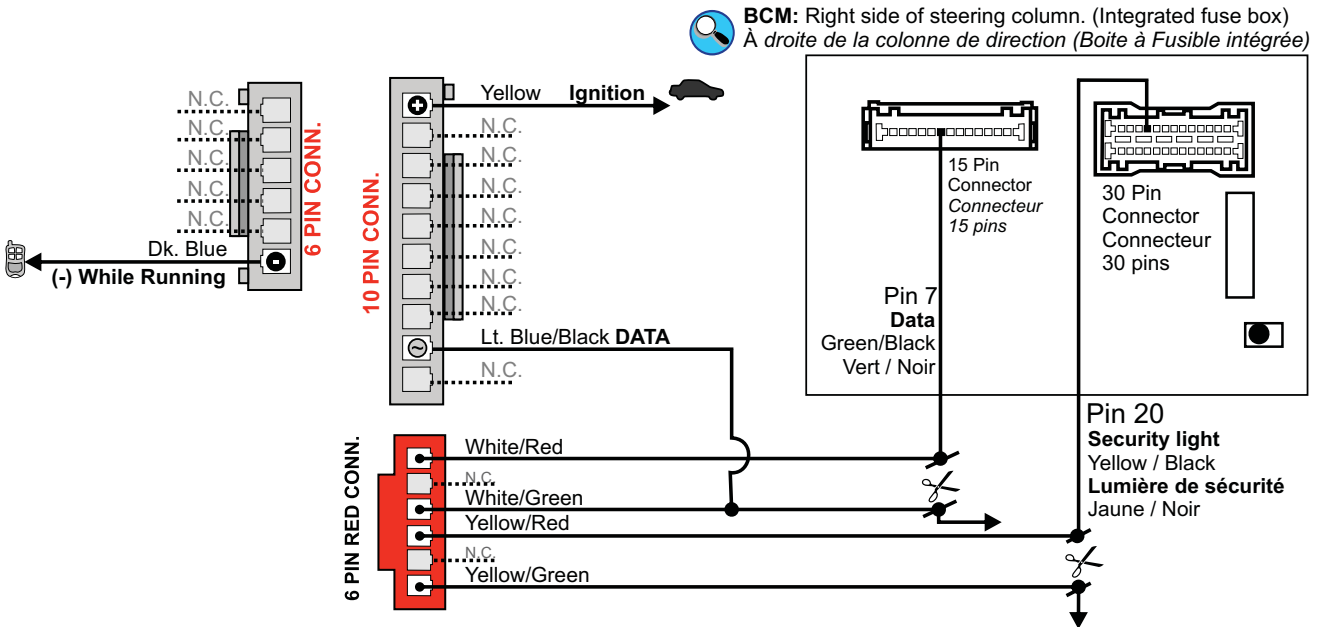

**CONNECTION 5**

**SUZUKI XL7**

**GO PROGRAM: 2**

**!** We recommend the installation with a **TBMG2** (transponder box) if the vehicle is not used regularly in cold weather. This configuration has a higher current consumption (+25mA) than other configurations. See Transponder Bypass (TBGM2) installation guide.



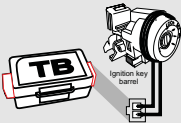
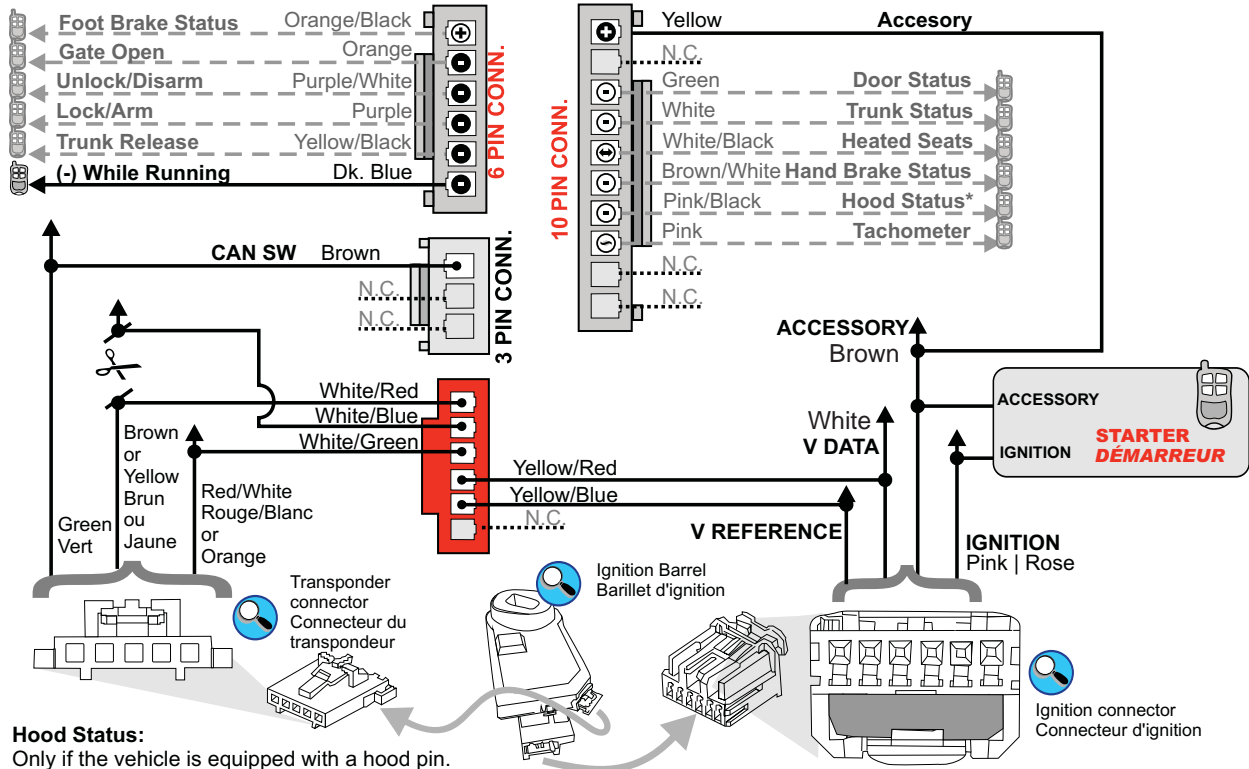





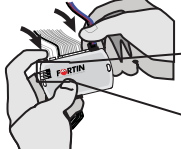
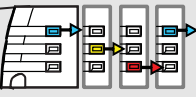
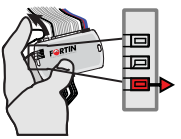

Nous recommandons l'installation avec **TBMG2** (Boîte Transpondeur) si le véhicule n'est pas utilisé régulièrement par temps froid. (Cette configuration à une consommation de courant plus élevé (+25mA) sur la batterie du véhicule. Voir le Guide d'installation du TBMG2

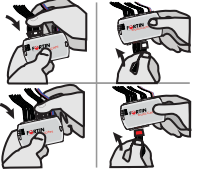

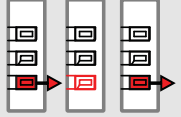



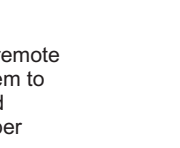
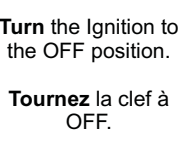
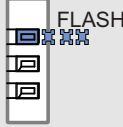

**!** **Hood Status:**  
Only if the vehicle is equipped with a hood pin.  
Seulement si le véhicule est équipé de la pin de capot.

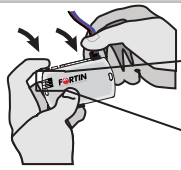
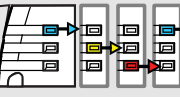
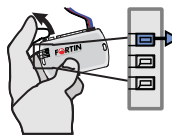
**PROGRAMMING PROCEDURE | PROCÉDURE DE PORGAMMATION**

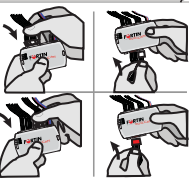
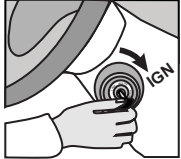
**PROGRAM. 1**

<b>1</b>					
					
<p><b>Press and hold</b> the programming button:</p> <p><b>Appuyez et maintenez enfoncé</b> le bouton de programmation:</p>	<p><b>Insert</b> the 4 Pin (Data-Link) connector.</p> <p><b>Insérez</b> le connecteur 4 pins (Data-Link).</p>	<p>The LED's will alternate between <b>BLUE, YELLOW and RED</b> flashes.</p> <p>Les DELS alternent entre un flash <b>BLEU, JAUNE et ROUGE</b>.</p>	<p><b>Release</b> the programming button when the LED is <b>RED.</b></p> <p><b>Relâchez</b> le bouton de programmation quand la DEL est <b>ROUGE.</b></p>	<p>If the LED is not solid <b>RED</b> disconnect the 4 Pin connector (Data-Link) and go back to step 1.</p> <p>Si le DEL n'est pas <b>ROUGE</b> solide débranchez le connecteur 4 pins (Data-Link) et allez à l'étape 1.</p>	<p><b>Insert</b> the remaining required connectors: 10 pin (White), 2 pin (White), 6 pin (White), 6 pin (Red), 3 pin (White).</p> <p><b>Insérez</b> les connecteurs requis restants: 10 pins (Blanc), 2 pins (Blanc), 6 pins (Blanc), 6 pins (Rouge) 3 pins (Blanc).</p>
<b>2</b>					
		<b>3</b>		<b>4</b>	
					
<p><b>Press and release</b> the programming button once (1x).</p> <p><b>Appuyez et relâchez</b> 1 fois le bouton de programmation.</p>	<p>The <b>RED LED</b> will turn <b>OFF</b> and then back <b>ON</b></p> <p>La <b>DEL ROUGE</b> s'éteint et se rallume.</p>	<p><b>Press and release</b> the programming button twice (2x).</p> <p><b>Appuyez et relâchez</b> 2 fois le bouton de programmation.</p>	<p>The <b>RED LED</b> will flash 2 times each second.</p> <p>La <b>DEL ROUGE</b> clignote 2 fois chaque seconde.</p>	<p><b>Turn</b> the Ignition to the <b>ON/RUN</b> position.</p> <p><b>Tournez</b> la clef en position <b>ignition (ON)</b>.</p>	<p>The <b>RED LED</b> will flash rapidly 10x times. Key bypass programmed.</p> <p>La <b>DEL ROUGE</b> clignotera 10x fois rapidement. Contournement de clé programmé.</p>
					
<p>The <b>BLUE LED</b> will flash rapidly. <b>CAN-Bus</b> programmed.</p> <p>La <b>DEL BLEU</b> clignotera rapidement: Réseau <b>CAN</b> programmé.</p>	<p><b>Turn</b> the Ignition to the <b>OFF</b> position.</p> <p><b>Tournez</b> la clef à <b>OFF</b>.</p>	<p>The module is now programmed.</p> <p>Le module est programmé.</p>			
<p>Use the remote of the remote starter or security system to test all of the supported features to ensure proper programming. Testez toutes les fonctions supportées sur le véhicule avec la télécommande du démarreur à distance ou du système de sécurité.</p>					

**PROGRAM. 2**

<p><b>1</b></p>  <p><b>Press and hold</b> the programming button:</p> <p><b>Appuyez et maintenez enfoncé</b> le bouton de programmation:</p>	 <p><b>Insert</b> the 4 Pin (Data-Link) connector.</p> <p><b>Insérez</b> le connecteur 4 pins (Data-Link).</p>	 <p><i>The LED's will alternate between BLUE, YELLOW and RED flashes. Les DELS alternent entre un flash BLEU, JAUNE et ROUGE.</i></p>	 <p><b>Release</b> the programming button when the LED is <b>BLUE.</b></p> <p><b>Relâchez</b> le bouton de programmation quand la DEL est <b>BLEU.</b></p>	<p>➤➤➤</p> <p>If the LED is not solid BLUE disconnect the 4 Pin connector (Data-Link) and go back to beginning of step 1.   Si le DEL n'est pas BLEU solide débranchez le connecteur 4 pins (Data-Link) et allez au début de l'étape 1.</p> 	<p><b>2</b></p>  <p><b>Insert</b> the remaining required connectors:</p> <p>10 pin (White), 2 pin (White), 6 pin (White), 6 pin (Red), 3 pin (White).</p> <p><b>Insérez</b> les connecteurs requis restants:</p> <p>10 pins (Blanc), 2 pins (Blanc), 6 pins (Blanc), 6 pins (Rouge), 3 pins (Blanc).</p>
<p><b>3</b></p>  <p><b>Turn</b> the Ignition to the ON/RUN position.</p> <p><b>Tournez</b> la clef en position <b>ignition (ON).</b></p>	  <p><i>Flash</i></p> <p><i>The BLUE LED will flash rapidly.</i></p> <p><i>La DEL BLEU clignotera rapidement.</i></p>	 <p><b>Turn</b> the Ignition to the OFF position.</p> <p><b>Tournez</b> la clef à OFF.</p>	  <p><i>Off</i></p> <p><i>The BLUE LED will turn off.</i></p> <p><i>Le DEL BLEU s'éteint.</i></p>	 <p><i>The module is now programmed.</i></p> <p><i>Le module est programmé.</i></p>	

**PROGRAM. 3**

**1**



**Press and hold** the programming button:

**Appuyez et maintenez enfoncé** le bouton de programmation:

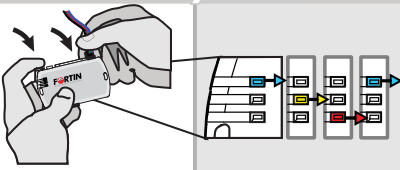

**Insert** the 4-Pin (Data-Link) connector.

**Insérez** le connecteur 4 pins (Data-Link).

The LED's will alternate between **BLUE, YELLOW and RED** flashes.

Les DELS alternent entre un flash **BLEU, JAUNE et ROUGE**.



**Release** the programming button when the LED is **YELLOW**.

**Relâchez** le bouton de programmation quand la DEL est **JAUNE**.

If the LED is not solid **YELLOW** disconnect the 4 Pin connector (Data-Link) and go back to step 1.

Si le DEL n'est pas **JAUNE** débranchez le connecteur 4 pins (Data-Link) et allez au début de l'étape 1.



**2**

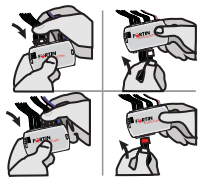

**Insert** the remaining required connectors:  
10 pin (White), 2 pin (White), 6 pin (White), 6 pin (Red), 3 pin (White).

**Insérez** les connecteurs requis restants:  
10 pins (Blanc), 2 pins (Blanc), 6 pins (Blanc), 6 pins (Rouge) 3 pins (Blanc).

**3**



**Press and release** the programming button twice (2x).

**Appuyez et relâchez** 2 fois le bouton de programmation.

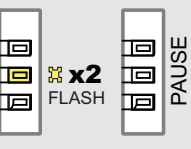

The **YELLOW LED** will alternate between 2x flashes and a pause.

La DEL **JAUNE** alterne entre 2x clignotements et x1 pause.

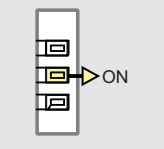

Wait until the **YELLOW LED** turns ON.

Attendre que la DEL **JAUNE** s'allume.



**Turn** the Ignition to the ON/RUN position.

**Tournez** la clef en position **ignition (ON)**.

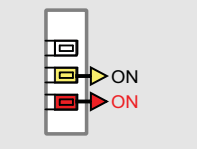

The **RED** will turn ON.

La DEL **ROUGE** s'allume.

If the **YELLOW** and **RED** LED's are not solid, **remove** the key and **go back** to step 4.

**Repeat** this step until the **RED** and **YELLOW** LED's are solid.

Si les DELs **JAUNE** et **ROUGE** ne sont pas allumées solide, **retirez** la clé et **recommencez** l'étape 4.

**Répétez** cette étape jusqu'à ce que les DELs **JAUNE** et **ROUGE** s'allument.

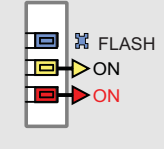
The **BLUE LED** will flash rapidly.

La DEL **BLEU** clignote rapidement.

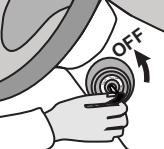

**Turn** the Ignition OFF.

**Tournez** la clef à OFF.



**Remove** the key from the ignition barrel.

**Retirez** la clé du barillet d'ignition.

**7**



**Reinsert** the key and **turn** the Ignition to the ON/RUN position.

**Réinsérez** la clé et **tournez** la clef en position ignition.

This process may take up to 3 minutes. La programmation peut prendre 3 minutes.

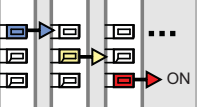

The **BLUE, YELLOW and RED** LED's will rapidly alternate.

Les DELs alternent rapidement entre **BLEU, JAUNE et ROUGE**.

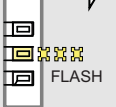

When the **YELLOW LED** begins to flash rapidly: Key bypass programmed.

Lorsque la DEL **JAUNE** clignote rapidement: Contournement de clé programmée.

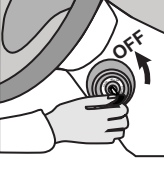

**Turn** the Ignition OFF.

**Tournez** la clef à OFF.



The module is now programmed.

Le module est programmé.

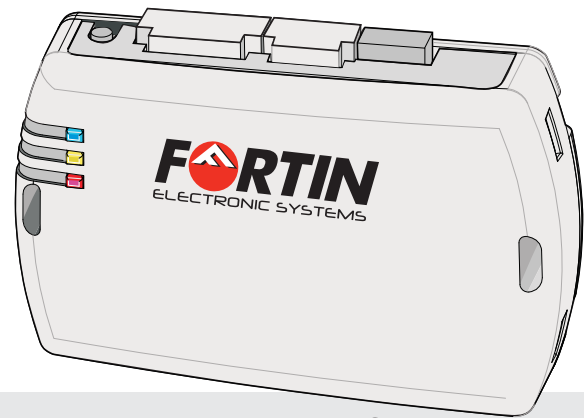

Module label | Étiquette sur le module

## **Notice:** Updated Firmware and Installation Guides

**Updated firmware and installation guides** are posted on our web site on a regular basis. We recommend that you update this module to the latest firmware and download the latest installation guide(s) prior to the installation of this product.

**Des mises à jour du Firmware (microprogramme) et des guides d'installation** sont mises en ligne régulièrement. Vérifiez que vous avez bien la dernière version logiciel et le dernier guide d'installation avant l'installation de ce produit.

## **WARNING / TECH SUPPORT / MISE EN GARDE / SUPPORT TECHNIQUE**

The information on this sheet is provided on an (as is) basis with no representation or warranty of accuracy whatsoever. It is the sole responsibility of the installer to check and verify any circuit before connecting to it. Only a computer safe logic probe or digital multimeter should be used. FORTIN ELECTRONIC SYSTEMS assumes absolutely no liability or responsibility whatsoever pertaining to the accuracy or currency of the information supplied. The installation in every case is the sole responsibility of the installer performing the work and FORTIN ELECTRONIC SYSTEMS assumes no liability or responsibility whatsoever resulting from any type of installation, whether performed properly, improperly or any other way. Neither the manufacturer or distributor of this module is responsible of damages of any kind indirectly or directly caused by this module, except for the replacement of this module in case of manufacturing defects. This module must be installed by qualified technician. The information supplied is a guide only. This instruction guide may change without notice. **Visit [www.fortinbypass.com](http://www.fortinbypass.com) to get the latest version.**

L'information de ce guide est fournie sur la base de représentation (telle quelle) sans aucune garantie de précision et d'exactitude. Il est de la seule responsabilité de l'installateur de vérifier tous les fils et circuit avant défectuer les connections. Seule une sonde logique ou un multimètre digital doivent être utilisés. FORTIN SYSTÈMES ÉLECTRONIQUES n'assume aucune responsabilité de l'exactitude de l'information fournie. L'installation (dans chaque cas) est la responsabilité de l'installateur effectuant le travail. FORTIN SYSTÈMES ÉLECTRONIQUES n'assume aucune responsabilité suite à l'installation, que celle-ci soit bonne ou mauvaise ou de n'importe autre type. Ni le fabricant, ni le distributeur ne se considèrent responsables des dommages causés ou ayant pu être causés, indirectement ou directement, par ce module, excepté le remplacement de ce module en cas de défectuosité de fabrication. Ce module doit être installé par un technicien qualifié. L'information fournie dans ce guide est une suggestion. Ce guide d'instruction peut faire l'objet de changement sans préavis. **Consultez le [www.fortinbypass.com](http://www.fortinbypass.com) pour voir la plus récente version.**

Copyright © 2006-2011, FORTIN AUTO RADIO INC ALL RIGHTS RESERVED **PATENT PENDING**



### **TECH SUPPORT**

Tél: 514-255-HELP (4357)  
1-877-336-7797



### **ADDENDUM GUIDE**

**[www.fortinbypass.com](http://www.fortinbypass.com)**  
WEB UPDATE | MISE À JOUR INTERNET

