

KIZASHI

ADDENDUM - SUGGESTED WIRING CONFIGURATION SCHEMA DE BRANCHEMENT SUGGERE



Parts required

- 1x 10A Fuse
- 3x 1A Diode
- 1x INSET (Sold separately)

Pièces requises

- 1x fusible 10A
- 3x Diodes 1A
- 1x INSET (Vendu séparément)

EVO-ALL Firmware version :4.02 and newer | et plus

Functional if equipped | Fonctionnelle si le véhicule en est équipé.

VEHICLES VEHICULES	YEARS ANNÉES	Lock	Unlock	Arm	Disarm	Hatch (open)	Trunk (open)	Sliding Door	Window Roll Down	Gas Door	RAP Disable	Parking Lights	Memory Driver	Tachometer	Defrost	Heated Seats	Heated Mirrors	Rear Defrost	Door Status	Trunk Status	Hood Status	Hand-Brake Status	Foot-Brake Status	Transponder Bypass	PK3, Passlock	Key Control	Activate OEM Remote	Start	Push-to-Start Control	SEE LEGEND
		A	B	C	D	E	F	G	H	I	J	K	L	M	N	O	P	Q	R	S	T	U	V	W	X	Y	Z	ZA	ZB	
SUZUKI Kizashi	Smart-Key	2011	•	•				•					•																	•

1 Fuse panel Boîte à fusible

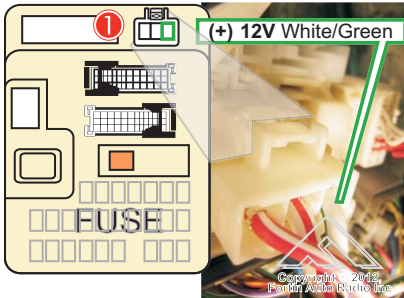

2 At Parking Light harness Au harnais des lumières de stationnement



3 OBDII

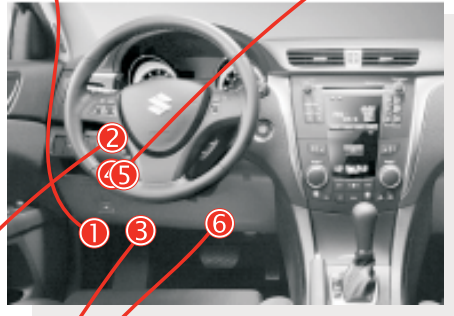
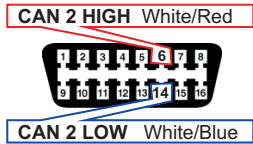

6 At clutch switch Au commutateur d'embrayage Manual Transmission

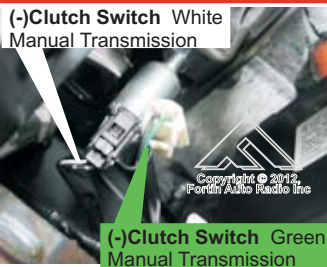

4 5 BCM

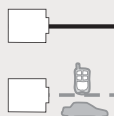
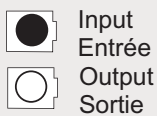
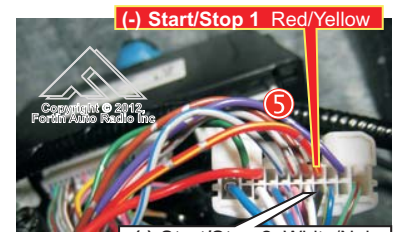
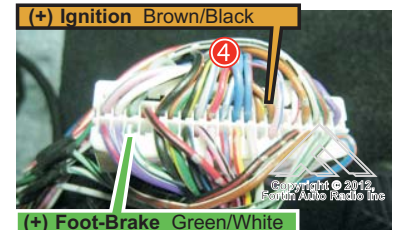

Connection always **required**
Branchement toujours **requis**

Connection **not required** with Data-link
Branchement **non requis** avec Data-Link



Connect to vehicle
Branchement au véhicule



Connect to Remote-Starter/Alarm
Branchement au démarreur à distance/Alarme

INSTALLATION WITH DATA-LINK INSTALLATION AVEC DATA-LINK

Remote Starter/Alarm with the Fortin Data-link protocol.
Démarreur à distance/alarme avec le protocole Data-link Fortin

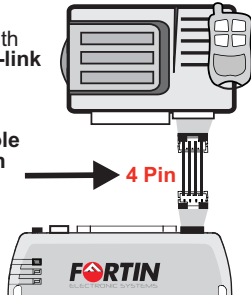

INSTALLATION WITHOUT DATA-LINK INSTALLATION SANS DATA-LINK

Remote Starter/Alarm
Démarreur à distance/alarme

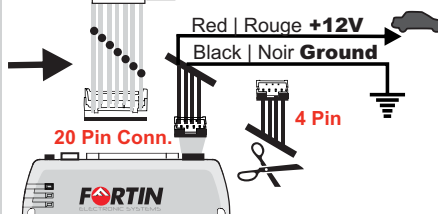

- 1 Cut off one plug of the 4 Pin Data-Link connector
- 2 Connect the Red wire to +12V
- 3 Connect the Black wire to Ground

- 1 Coupez l'extrémité du connecteur 4 pins Data-Link
- 2 Connectez le fil rouge au 12V
- 3 Connectez le fil noir à la masse du véhicule.

KIZASHI - Automatic transmission - CONTINUED | SUITE

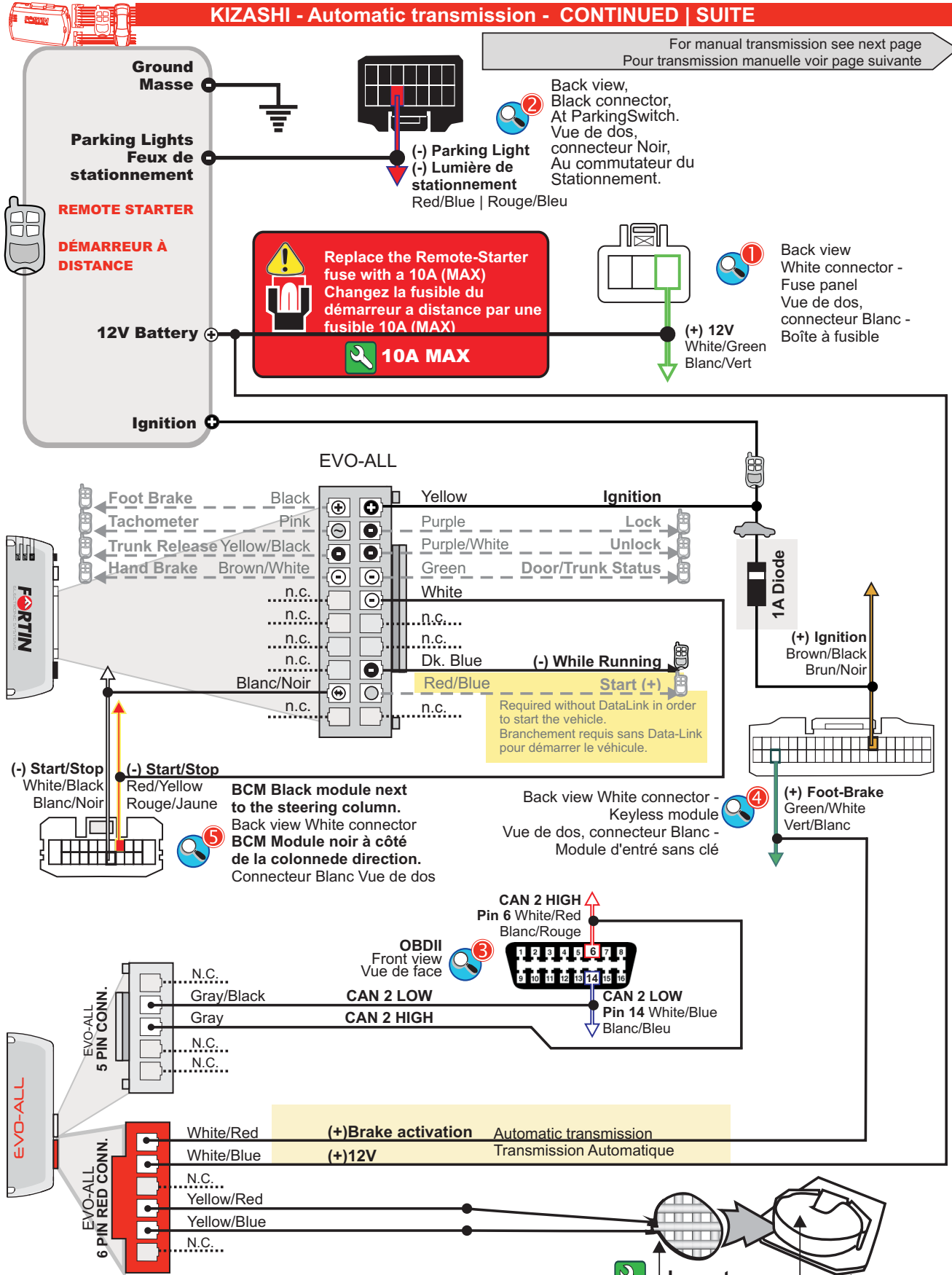

Open the remote. Trim the INSET. It must be the same size of the battery. Insert the control membrane INSET between the battery and the circuit board of the remote control. Reassemble the remote.

Ouvrez la télécommande. Coupez les rebords de l'INSET de façon à se qu'il soit de la même grosseur que la batterie. Insérez la membrane de contrôle INSET entre la batterie et le circuit de la télécommande. Réassemblez la télécommande.



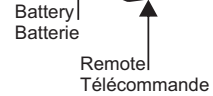

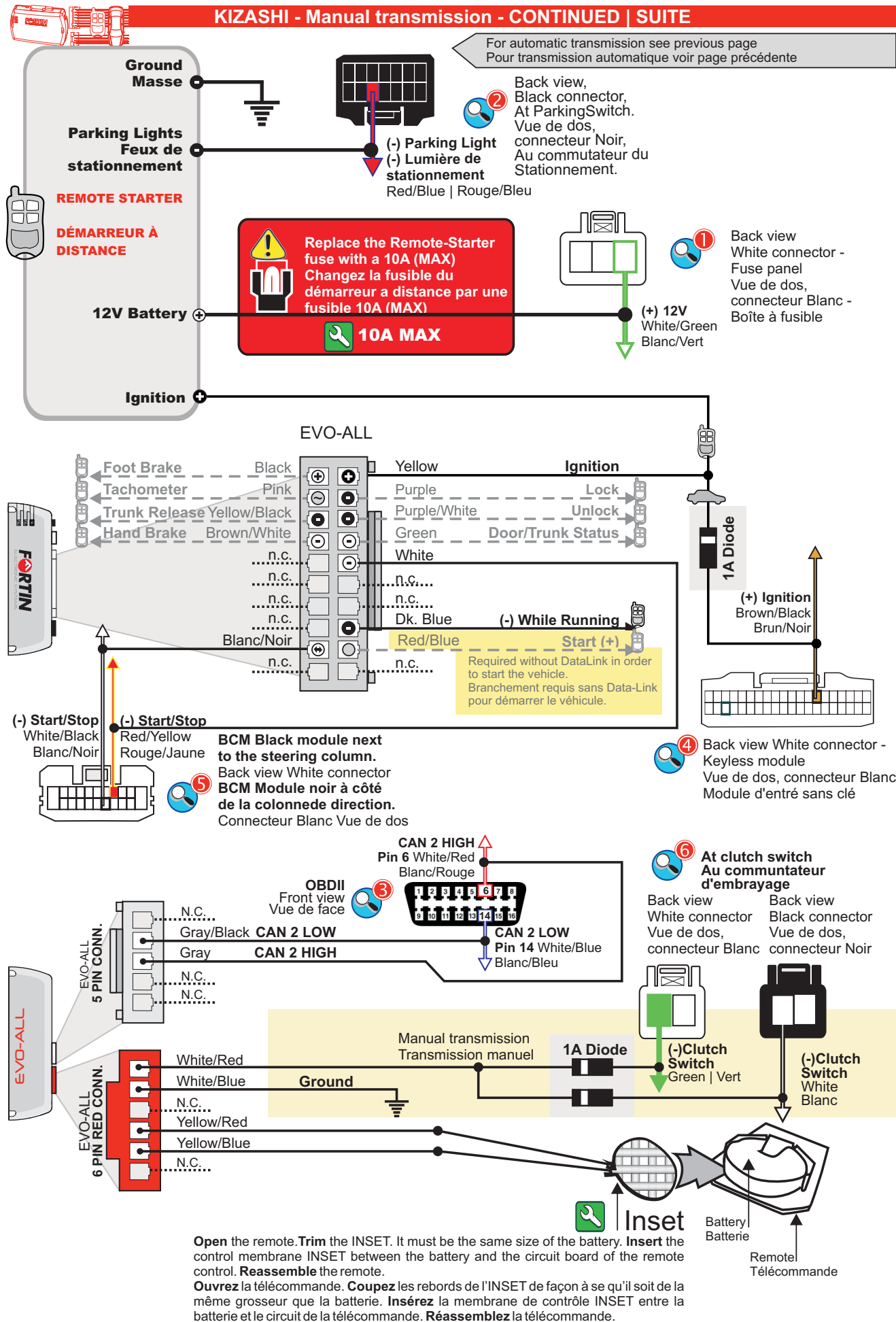

Inset



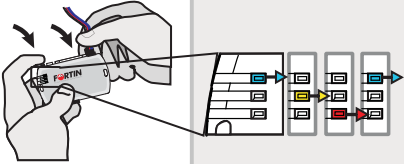
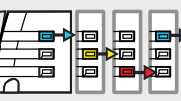
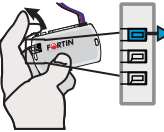
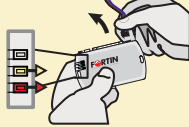
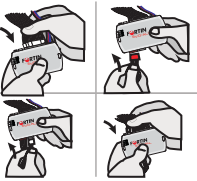

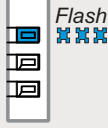

KIZASHI - Manual transmission - CONTINUED | SUITE



PROGRAMMING PROCEDURE | PROCÉDURE DE PROGRAMMATION

1	2				
					
<p>Press and hold the programming button:</p> <p>Appuyez et maintenez enfoncé le bouton de programmation:</p>	<p>Insert the 4 Pin (Data-Link) connector.</p> <p>Insérez le connecteur 4 pins (Data-Link).</p>	<p><i>The LED will alternate between BLUE, YELLOW and RED flashes. Les DELS alternent entre un flash BLEU, JAUNE et ROUGE.</i></p>	<p>Release the programming button when the LED is BLUE.</p> <p>Relâchez le bouton de programmation quand la DEL est BLEU.</p>	<p>If the LED is not solid BLUE disconnect the 4 Pin connector (Data-Link) and go back to beginning of step 1. Si le DEL n'est pas BLEU solide débranchez le connecteur 4 pins (Data-Link) et allez au début de l'étape 1.</p>	<p>Insert the required remaining connectors:</p> <p>20 pin (White), 5 pin (White), 6 pin (Red), 2 pin (White).</p> <p>Insérez les connecteurs requis restants:</p> <p>20 pins (Blanc), 2 pins (Blanc), 5 pins (Blanc), 6 pins (Rouge).</p>
3					
<p>Press the Push-to-Start button twice to turn on the ignition. (Do not press the brake pedal)</p> <p>Appuyez 2 fois sur le bouton démarrage (Push-to-Start) pour allumer l'ignition. (Ne pas appuyer sur la pédale de frein)</p>	<p><i>Once the Blue LED starts to flash rapidly: Lorsque le DEL Bleu clignote rapidement:</i></p>	<p>press the Push-to-Start button once to shut off the ignition.</p> <p>appuyez une fois sur le bouton démarrage (Push-to-Start) pour éteindre l'ignition.</p>	<p><i>The LED will turn off. Le DEL s'éteint.</i></p>	<p><i>The module is now programmed. Le module est programmé.</i></p>	

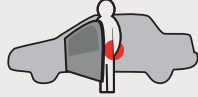
REMOTE STARTER FUNCTIONALITY | FONCTIONNALITÉS DU DÉMARREUR À DISTANCE

				
<p>All doors must be closed.</p> <p>Toutes les portes doivent être fermées</p>	<p>Remote start the vehicle.</p> <p>Démarrez à distance.</p>	<p>Press the Unlock button of the remote car starter.</p> <p>Appuyez sur le bouton Déverrouillage de la télécommande du démarreur à distance.</p>	<p>Enter the vehicle with the Intelligent Access Key.</p> <p>Entrez dans le véhicule avec la clé intelligente (Access Key) sur vous</p>	<p><i>The vehicle can now be put in to gear and driven.</i></p> <p><i>Vous êtes maintenant prêt à embrayer et prendre la route.</i></p>

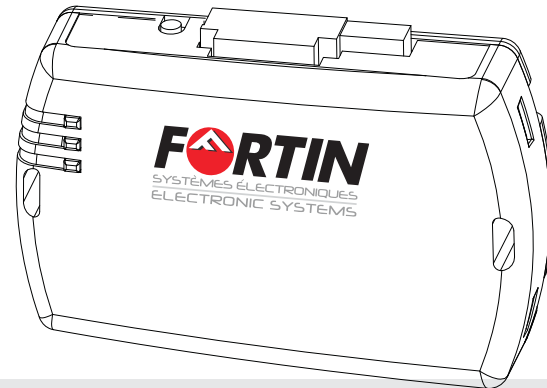

Module label | Étiquette sur le module

Notice: Updated Firmware and Installation Guides

Updated firmware and installation guides are posted on our web site on a regular basis. We recommend that you update this module to the latest firmware and download the latest installation guide(s) prior to the installation of this product.

Des mises à jour du Firmware (microprogramme) et des guides d'installation sont mises en ligne régulièrement. Vérifiez que vous avez bien la dernière version logiciel et le dernier guide d'installation avant l'installation de ce produit.

WARNING / TECH SUPPORT / MISE EN GARDE / SUPPORT TECHNIQUE

The information on this sheet is provided on an (as is) basis with no representation or warranty of accuracy whatsoever. It is the sole responsibility of the installer to check and verify any circuit before connecting to it. Only a computer safe logic probe or digital multimeter should be used. FORTIN ELECTRONIC SYSTEMS assumes absolutely no liability or responsibility whatsoever pertaining to the accuracy or currency of the information supplied. The installation in every case is the sole responsibility of the installer performing the work and FORTIN ELECTRONIC SYSTEMS assumes no liability or responsibility whatsoever resulting from any type of installation, whether performed properly, improperly or any other way. Neither the manufacturer or distributor of this module is responsible of damages of any kind indirectly or directly caused by this module, except for the replacement of this module in case of manufacturing defects. This module must be installed by qualified technician. The information supplied is a guide only. This instruction guide may change without notice. **Visit www.fortinbypass.com to get the latest version.**

L'information de ce guide est fournie sur la base de représentation (telle quelle) sans aucune garantie de précision et d'exactitude. Il est de la seule responsabilité de l'installateur de vérifier tous les fils et circuit avant défectuer les connections. Seule une sonde logique ou un multimètre digital doivent être utilisés. FORTIN SYSTÈMES ÉLECTRONIQUES n'assume aucune responsabilité de l'exactitude de l'information fournie. L'installation (dans chaque cas) est la responsabilité de l'installateur effectuant le travail. FORTIN SYSTÈMES ÉLECTRONIQUES n'assume aucune responsabilité suite à l'installation, que celle-ci soit bonne ou mauvaise ou de n'importe autre type. Ni le fabricant, ni le distributeur ne se considèrent responsables des dommages causés ou ayant pu être causés, indirectement ou directement, par ce module, excepté le remplacement de ce module en cas de défectuosité de fabrication. Ce module doit être installé par un technicien qualifié. L'information fournie dans ce guide est une suggestion. Ce guide d'instruction peut faire l'objet de changement sans préavis. **Consultez le www.fortinbypass.com pour voir la plus récente version.**

Copyright © 2006-2011, FORTIN AUTO RADIO INC ALL RIGHTS RESERVED **PATENT PENDING**



TECH SUPPORT

Tél: 514-255-HELP (4357)
1-877-336-7797



ADDENDUM GUIDE

www.fortinbypass.com

WEB UPDATE | MISE À JOUR INTERNET

