

# EVO-CAN

Guide #3025

## HONDA / ACURA



HONDA



ACURA

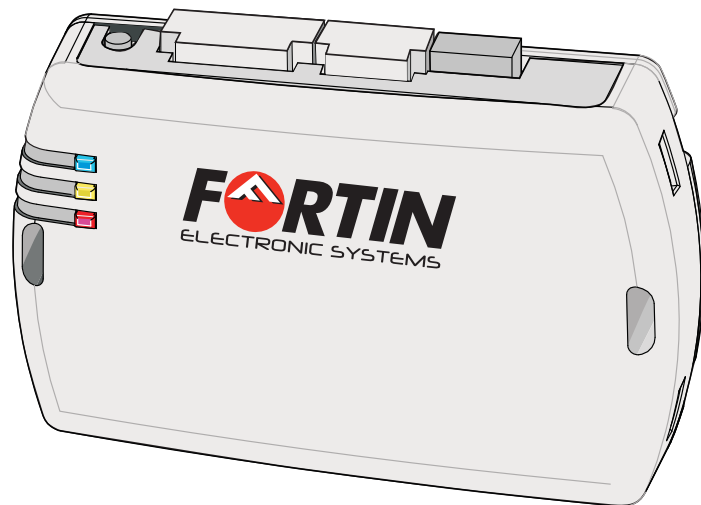

Module label | Étiquette sur le module

### **Notice:** Updated Firmware and Installation Guides

**Updated firmware and installation guides** are posted on our web site on a regular basis. We recommend that you update this module to the latest firmware and download the latest installation guide(s) prior to the installation of this product.

**Des mises à jour du Firmware (microprogramme) et des guides d'installation** sont mises en ligne régulièrement. Vérifiez que vous avez bien la dernière version logiciel et le dernier guide d'installation avant l'installation de ce produit.



### TECH SUPPORT

Tél: 514-255-HELP (4357)  
1-877-336-7797



### ADDENDUM GUIDE

Rev : 20120412

[www.fortinbypass.com](http://www.fortinbypass.com)

WEB UPDATE | MISE À JOUR INTERNET



# WIRE LEGEND | LEGENDE

Input | *Entrée*    Output | *Sortie*

Connection always **required**  
*Branchement toujours requis*

Connection **not required** with Data-link  
*Branchement **non requis** avec Data-Link*

Connect to vehicle  
*Branchement au véhicule*

Connect to Remote-Starter/Alarm  
*Branchement au démarreur à distance/Alarme*

Cut | *Couper*

**NOTE:**

All possible functions are summarized in each configuration, however some functions may not be supported on all vehicles. Refer to the VEHICLE FIT GUIDE to determine the supported functions for a specific vehicle.  
Toutes les fonctions possibles sont écrites dans chaque configuration, toutefois elles ne sont pas toutes supportées par tous les véhicules. Voir le GUIDE DES VÉHICULES pour déterminer les fonctions supportées sur chaque véhicule.

# DESCRIPTION

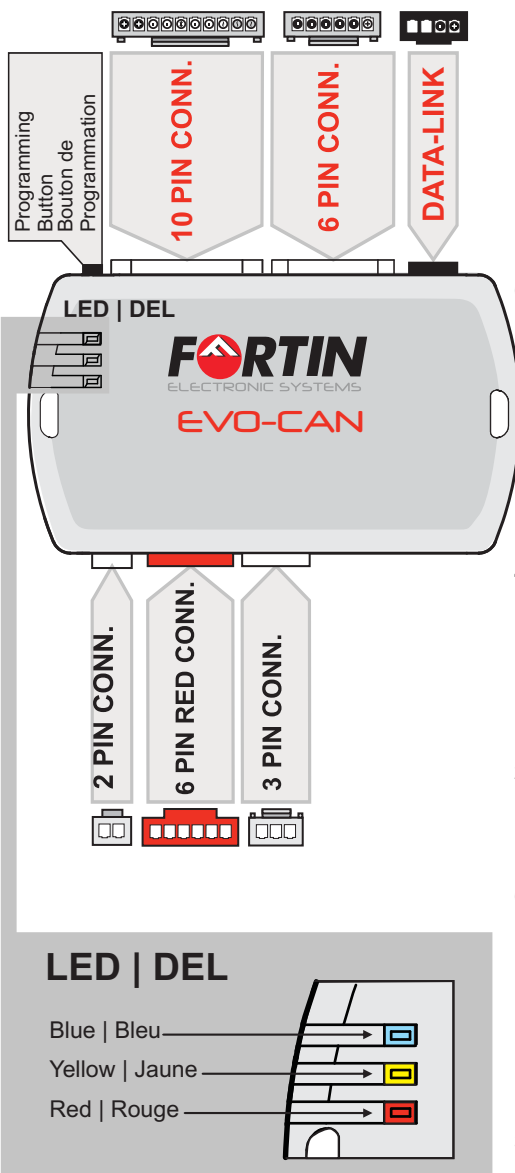

**10 PIN CONNECTOR: MAIN HARNESS | HARNAIS PRINCIPAL (WHITE|BLANC)**

|                                 |   |
|---------------------------------|---|
| Yellow   Jaune                  | Ignition                                |
| Red/Blue   Rouge/Bleu           | Start                                   |
| Green   Vert                    | Door Status   Statuts Portes            |
| White   Blanc                   | Trunk Status   Statuts Valise           |
| White/Black   Blanc/Noir        | AUX2 / KEY SENSE                        |
| Brown/White   Brun/Blanc        | Hand Brake Status   Frein à Main Signal |
| Pink/Black   Rose/Noir          | Hood Status   Capot Statuts             |
| Pink   Rose                     | Tachometer                              |
| Lt. Blue/Black   Bleu Pâle/Noir | DATA 1 See configuration                |
| Lt. Blue   Bleu Pâle            | DATA 2 See configuration                |

**6 PIN CONNECTOR: MAIN HARNESS | HARNAIS PRINCIPAL (WHITE|BLANC)**

|                            |  |
|----------------------------|--|
| Orange/Black   Orange/Noir | Foot Brake Status   Statuts Frein (pied) |
| Orange                     | AUX 1                                    |
| Purple/White   Mauve/Blanc | Unlock/Disarm   Déverrouille/Désarme     |
| Purple   Mauve             | Lock/Arm   Verrouille/Arme               |
| Yellow/Black   Jaune/Noir  | Trunk Release   Valise                   |
| Dk. Blue   Bleu foncé      | GWR (Ground While Running)               |

**4 PIN CONNECTOR: DATA-LINK (BLACK | NOIR) SEE PAGE 3 | VOIR PAGE 3**

|               |                                    |
|---------------|------------------------------------|
| Red   Rouge   | (+) 12V Battery   (+) 12V Batterie |
| Black   Noir  | Ground (-)   Masse (-)             |
| Blue   Bleu   | DATA                               |
| White   Blanc | DATA                               |

**2 PIN CONNECTOR: TB CONTROL (WHITE | BLANC)**

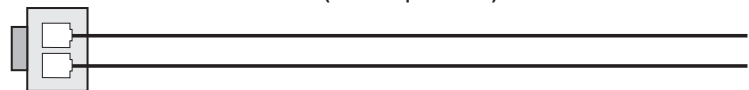

**6 PIN CONNECTOR: RELAY | RELAIS (RED | ROUGE)**

|                           |       |
|---------------------------|-------|
| White/Red   Blanc/Rouge   | COMM2 |
| White/Blue   Blanc/Bleu   | NO2   |
| White/Green   Blanc/Vert  | NC2   |
| Yellow/Red   Jaune/Rouge  | COMM1 |
| Yellow/Blue   Jaune/Bleu  | NO1   |
| Yellow/Green   Jaune/Vert | NC1   |

**3 PIN CONNECTOR: CAN-BUS (WHITE | BLANC)**

|                        |                 |
|------------------------|-----------------|
| Brown   Brun           | CAN 1 WIRE (SW) |
| Gray/Black   Gris/Noir | CAN LOW         |
| Gray   Gris            | CAN HIGH        |

**LED | DEL**

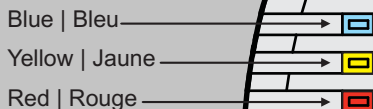

# INSTALLATION PROCEDURE

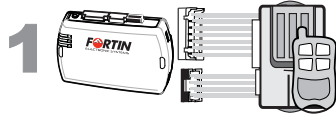

**Determine if the remote-starter or alarm system supports 2-way Data-Link.**

**Déterminez si le démarreur à distance ou système d'alarme est compatible en Data-Link 2-voies.**

## WITH DATA-LINK AVEC DATA-LINK

In order to utilize this type of connection the remote-starter or alarm-system must be compatible with the **Fortin Data-link protocol**. Consult the installation guide or visit [www.fortinbypass.com/datalink/](http://www.fortinbypass.com/datalink/) for more information.

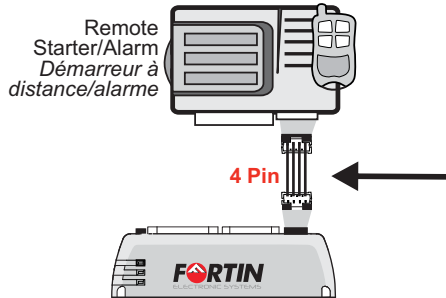

Le démarreur à distance ou le système d'alarme doit être compatible avec le **protocole Data-link Fortin** pour ces branchements. Consultez le guide d'installation du démarreur à distance ou du système d'alarme ou visitez le [www.fortinbypass.com/datalink/](http://www.fortinbypass.com/datalink/) pour plus d'informations.

## WITH OUT DATA-LINK SANS DATA-LINK

For all other remote-starters or alarm-systems perform the following connections.

Pour tout autres types de démarreurs à distance ou d'alarme, effectuez les branchements suivants.

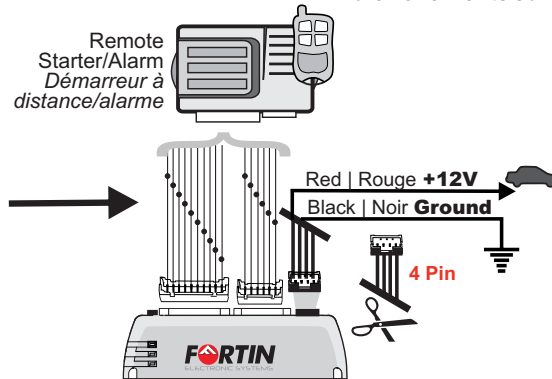

- 1 Cut off one plug of the 4 Pin Data-Link connector
- 2 Connect the Red wire to +12V
- 3 Connect the Black wire to Ground

- 1 Coupez l'extrémité du connecteur 4 pins Data-Link
- 2 Connectez le fil rouge au 12V
- 3 Connectez le fil noir à la masse du véhicule.



**Make the connections:**

**Faire les branchements:**



**10 Pin Connector (White):**  
Make the connections associated with the vehicle from the VEHICLE FIT GUIDE.

**10 Pins Connecteur (Blanc):**  
Effectuez les branchements associés au véhicule dans le GUIDE DES VÉHICULES.



**6 Pin Connector (White):**  
Make the connections (if required)

**6 Pins Connecteur (Blanc):**  
Effectuez les branchements.(Si nécessaire)



**3 Pin Connector CAN (White):**  
Make the connections (if required)

**3 Pins Connecteur CAN (Blanc):**  
Effectuez les branchements.(Si nécessaire)



**6 Pin Connector RELAY (Red):**  
Make the connections (if required)

**6 Pins Connecteur RELAI (Rouge):**  
Effectuez les branchements.(Si nécessaire)



**2 Pin Connector (White):**  
Make the connections (if required)

**2 Pins Connecteur (Blanc):**  
Effectuez les branchements.(Si nécessaire)



## PROGRAMMING PROCEDURE

## PROCÉDURE DE PROGRAMMATION

Determine the programming procedure required for the vehicle in the VEHICLE FIT GUIDE.

Déterminez le type de programmation selon votre véhicule dans le GUIDE DES VÉHICULES.

Connection number  
Numéro de connexion

Vehicle(s) associated with the procedure  
Véhicule(s) associé(s) à la configuration

Programming number  
Numéro de programmation

**CONNECTION #**

**VEHICLE MAKE MODEL YEAR**

**PROGRAM: #**

**VEHICLE FIT GUIDE | GUIDE DES VÉHICULES**

|                       |                                   |            |             | Functional if equipped   Fonctionnelle si le véhicule en est équipé. |        |     |        |              |              |              |                  |          |             |               |               |            |              |                |              |             |              |             |                   |                   |                    |               |             | See Legend Below          |                       |        |  |
|-----------------------|-----------------------------------|------------|-------------|--|--------|-----|--------|--------------|--------------|--------------|------------------|----------|-------------|---------------|---------------|------------|--------------|----------------|--------------|-------------|--------------|-------------|-------------------|-------------------|--------------------|---------------|-------------|---------------------------|-----------------------|--------|--|
| VEHICLES   VEHICULES  | YEARS ANNÉES                      | Connection | Programming | Lock   | Unlock | Arm | Disarm | Hatch (open) | Trunk (open) | Sliding Door | Window Roll Down | Gas Door | RAP Disable | Parking Light | Memory Driver | Tachometer | Heated Seats | Heated Mirrors | Rear Defrost | Door Status | Trunk Status | Hood Status | Hand-Brake Status | Foot-Brake Status | Transponder Bypass | PK3, Passlock | Key Control | Activate OEM Remote Start | Push-to-Start Control | Legend |  |
|                       |                                   |            |             | A  | B      | C   | D      | E            | F            | G            | H                | I        | J           | K             | L             | M          | O            | P              | Q            | R           | S            | T           | U                 | V                 | W                  | X             | Y           | Z                         | ZA                    | ZB     |  |
| <b>ACURA</b>          |                                   |            |             |  |        |     |        |              |              |              |                  |          |             |               |               |            |              |                |              |             |              |             |                   |                   |                    |               |             |                           |                       |        |  |
| CSX                   | 2006-2011                         | 8          | 1           | •  | •      | •   | •      |              | •            |              |                  |          |             |               |               | •          |              |                |              | •           | •            |             | •                 | •                 | •                  |               |             |                           |                       |        |  |
| EL 1.7                | 2001-2005                         | 2          | 1           |  |        |     |        |              |              |              |                  |          |             |               |               |            |              |                |              |             |              |             |                   |                   |                    |               |             |                           |                       |        |  |
| MDX                   | 2003-2006                         | 2          | 1           |  |        |     |        |              |              |              |                  |          |             |               |               |            |              |                |              |             |              |             |                   |                   |                    |               |             |                           |                       |        |  |
|                       | 2007-2012                         | 3          | 1           | •  | •      | •   | •      |              | •            |              |                  |          |             |               |               |            |              |                |              | •           | •            | •           | •                 | •                 | •                  |               |             |                           |                       |        |  |
| RDX                   | 2007-2012                         | 8          | 1           | •  | •      | •   | •      |              |              |              |                  |          |             |               |               | •          |              |                |              | •           | •            | •           | •                 | •                 | •                  |               |             |                           |                       |        |  |
| RL                    | 1998-2004                         | 5          | 1           | •  | •      | •   | •      |              |              |              |                  |          |             |               |               |            |              |                |              |             |              |             |                   |                   |                    |               |             |                           |                       |        |  |
|                       | 2005-2012                         | 6          | 1           | •  | •      | •   | •      |              | •            |              |                  |          |             |               |               | •          |              |                |              | •           | •            | •           | •                 | •                 | •                  |               |             |                           |                       |        |  |
| RSX                   | 2002-2006                         | 2          | 1           |  |        |     |        |              |              |              |                  |          |             |               |               |            |              |                |              |             |              |             |                   |                   |                    |               |             |                           |                       |        |  |
| TL                    | 2004-2008                         | 1          | 1           | •  | •      | •   | •      |              | •            |              |                  |          |             |               |               | •          |              |                |              | •           | •            | •           | •                 | •                 | •                  |               |             |                           |                       |        |  |
|                       | 2009-2012                         | 4          | 1           | •  | •      | •   | •      |              | •            |              |                  |          |             |               |               |            |              |                |              | •           | •            | •           | •                 | •                 | •                  |               |             |                           |                       |        |  |
|                       | <i>Push-to-Start</i> 2011         | 9          | 2           | •  | •      | •   | •      |              | •            |              |                  |          |             |               | •             |            |              |                |              | •           | •            | •           | •                 | •                 | •                  |               |             |                           |                       |        |  |
| TSX                   | 2004-2008                         | 1          | 1           | •  | •      | •   | •      |              | •            |              |                  |          |             |               |               | •          |              |                |              | •           | •            | •           | •                 | •                 | •                  |               |             |                           |                       |        |  |
|                       | 2009-2012                         | 4          | 1           | •  | •      | •   | •      |              | •            |              |                  |          |             |               |               | •          |              |                |              | •           | •            | •           | •                 | •                 | •                  |               |             |                           |                       |        |  |
| <b>HONDA</b>          |                                   |            |             |  |        |     |        |              |              |              |                  |          |             |               |               |            |              |                |              |             |              |             |                   |                   |                    |               |             |                           |                       |        |  |
| Accord                | 2003-2007                         | 1          | 1           | •  | •      | •   | •      |              | •            |              |                  |          |             |               |               | •          |              |                |              | •           | •            | •           | •                 | •                 | •                  |               |             |                           |                       |        |  |
|                       | 2008-2012                         | 4          | 1           | •  | •      | •   | •      |              | •            |              |                  |          |             |               |               | •          |              |                |              | •           | •            | •           | •                 | •                 | •                  |               |             |                           |                       |        |  |
|                       | <i>Accord Hybrid</i> 2005-2007    | 1          | 1           | •  | •      | •   | •      |              | •            |              |                  |          |             |               |               | •          |              |                |              | •           | •            | •           | •                 | •                 | •                  |               |             |                           |                       |        |  |
|                       | <i>Accord Crosstour</i> 2010-2012 | 4          | 1           | •  | •      | •   | •      |              | •            |              |                  |          |             |               |               | •          |              |                |              | •           | •            | •           | •                 | •                 | •                  |               |             |                           |                       |        |  |
| Civic or Civic Hybrid | 2001-2005                         | 2          | 1           |  |        |     |        |              |              |              |                  |          |             |               |               |            |              |                |              |             |              |             |                   |                   |                    |               |             |                           |                       |        |  |
|                       | 2006-2011                         | 8          | 1           | •  | •      | •   | •      |              | •            |              |                  |          |             |               |               | •          |              |                |              | •           | •            | •           | •                 | •                 | •                  |               |             |                           |                       |        |  |
|                       | 2012                              | 7          | 1           | •  | •      | •   | •      |              | •            |              |                  |          |             |               |               | •          |              |                |              | •           | •            | •           | •                 | •                 | •                  |               |             |                           |                       |        |  |
| CR-V                  | 2002-2006                         | 2          | 1           |  |        |     |        |              |              |              |                  |          |             |               |               |            |              |                |              |             |              |             |                   |                   |                    |               |             |                           |                       |        |  |
|                       | 2007-2011                         | 8          | 1           | •  | •      | •   | •      |              | •            |              |                  |          |             |               |               | •          |              |                |              | •           | •            | •           | •                 | •                 | •                  |               |             |                           |                       |        |  |
|                       | 2012                              | 10         | 1           | •  | •      | •   | •      |              | •            |              |                  |          |             |               |               | •          |              |                |              | •           | •            | •           | •                 | •                 | •                  |               |             |                           |                       |        |  |
| CR-Z                  | 2011                              | 8          | 1           |  |        | •   | •      |              | •            |              |                  |          |             |               |               | •          |              |                |              | •           | •            | •           | •                 | •                 | •                  |               |             |                           |                       |        |  |
| Element               | 2003-2010                         | 2          | 1           |  |        |     |        |              |              |              |                  |          |             |               |               |            |              |                |              |             |              |             |                   |                   |                    |               |             |                           |                       |        |  |
| Fit                   | 2006-2008                         | 2          | 1           |  |        |     |        |              |              |              |                  |          |             |               |               |            |              |                |              |             |              |             |                   |                   |                    |               |             |                           |                       |        |  |
|                       | 2009-2012                         | 8          | 1           | •  | •      | •   | •      |              | •            |              |                  |          |             |               |               | •          |              |                |              | •           | •            | •           | •                 | •                 | •                  |               |             |                           |                       |        |  |
| Insight               | 2010-2012                         | 8          | 1           | •  | •      | •   | •      |              | •            |              |                  |          |             |               |               | •          |              |                |              | •           | •            | •           | •                 | •                 | •                  |               |             |                           |                       |        |  |
| Odyssey               | 2005-2010                         | 1          | 1           | •  | •      | •   | •      |              | •            |              |                  |          |             |               |               | •          |              |                |              | •           | •            | •           | •                 | •                 | •                  |               |             |                           |                       |        |  |
|                       | 2011-2012                         | 4          | 1           | •  | •      | •   | •      |              | •            |              |                  |          |             |               |               | •          |              |                |              | •           | •            | •           | •                 | •                 | •                  |               |             |                           |                       |        |  |
| Pilot                 | 2005-2008                         | 2          | 1           |  |        |     |        |              |              |              |                  |          |             |               |               |            |              |                |              |             |              |             |                   |                   |                    |               |             |                           |                       |        |  |
|                       | 2009-2012                         | 4          | 1           | •  | •      | •   | •      |              | •            |              |                  |          |             |               |               | •          |              |                |              | •           | •            | •           | •                 | •                 | •                  |               |             |                           |                       |        |  |
| Prelude               | 1997-2001                         | 5          | 1           |  |        |     |        |              |              |              |                  |          |             |               |               |            |              |                |              |             |              |             |                   |                   |                    |               |             |                           |                       |        |  |
| Ridgeline             | 2006-2011                         | 1          | 1           | •  | •      | •   | •      |              | •            |              |                  |          |             |               |               | •          |              |                |              | •           | •            | •           | •                 | •                 | •                  |               |             |                           |                       |        |  |
| S2000                 | 2004-2007                         | 2          | 1           |  |        |     |        |              |              |              |                  |          |             |               |               |            |              |                |              |             |              |             |                   |                   |                    |               |             |                           |                       |        |  |

**LEGEND | LÉGENDE**

- 1 - **TB-GM2\*** for transponder bypass pour contournement du transpondeur
  - 2 - **TB-KIA1\*** for transponder bypass pour contournement du transpondeur
  - 3 - **TB-KIA2\*** for transponder bypass pour contournement du transpondeur
  - 4 - **TB-MITS2\*** for transponder bypass pour contournement du transpondeur
  - 5 - Heated seats will only turn ON (low power) if the engine temperature is below 0°C (32°F) when remote started.  
Les sièges chauffants s'allument à faible intensité SEULEMENT si la température du moteur est sous 0°C
  - 6 - **INT-BMW1\*** for remote car starter | Pour démarreur à distance
  - 7 - **TB-SUBARU1 or 2\*** for transponder bypass | pour contournement du transpondeur
  - 8 - A special diagram is required for Remote car starter : www.fortinbypass.com  
Un diagramme spécial est requis pour démarreur à distance : www.fortinbypass.com
  - 9 - **INSET\*** for remote car starter | Pour démarreur à distance
  - 10 - **EVO-CAN** version hardware 3+ required | version du matériel: 3+ requis
  - 11 - **EVO-RIDE** for transponder bypass | pour contournement du transpondeur
- \* Sold separately | Vendu séparément

**Key Control :** (Contrôle de la Clé) KEY REQUIRED. Transponder bypass by wrapping of factory key. CLÉ REQUISE. The EVO-CAN activates the relay on connector 2 (White wire) during remote start. Contournement du transpondeur par enroulement de la clé d'origine. Le EVO-CAN active le relais du connecteur 2 pin Blanc lors du démarrage à distance.

**Activate OEM Remote Start :** (Active Démarreur d'origine) The EVO-CAN activates the factory remote starter if the vehicle has one equipped. Le EVO-CAN active le démarreur à distance d'origine lorsque le véhicule en est équipé.

**Push-to-Start Control :** (Contrôle Bouton Démarreur) For Push-to-Start vehicles, the EVO-CAN activates the push button to allow seamless takeover by the user. Pour les véhicules équipés de bouton Push-to-Start, le EVO-CAN actionne le bouton dans le but d'éviter à l'utilisateur de le faire avant de conduire le véhicule.

# CONNECTION

## CONNECTION 1

PROGRAM: 1

| ACURA YEARS | Data Pin 2     | CAN SW Pin 4 | Security Light Pin 5 | Ignition Pin 6 | HONDA YEARS | Data Pin 2     | CAN SW Pin 4 | Security Light Pin 5 | Ignition Pin 6 |
|-------------|----------------|--------------|----------------------|----------------|-------------|----------------|--------------|----------------------|----------------|
| TL          | 04-06 Red/Blue | Brown/Black  | Blue/Orange          | Black/Green    | Accord      | 03-07 Red/Blue | Brown/Red    | Blue/Orange          | Black/Yellow   |
|             | 07-08 Yellow   | Brown/Black  | Orange               | Black/Green    | Hybrid      | 05 Yellow      | Lt Green     | Red                  | Black/Yellow   |
| TSX         | 04-05 Red/Blue | Brown/Red    | Blue/Orange          | Black/Yellow   | Hybrid      | 06-07 Yellow   | Brown/Red    | Red                  | Black/Yellow   |
|             | 06-08 Yellow   | Brown/Red    | Orange               | Black/Yellow   | Odyssey     | 05-10 Red/Blue | Green/Red    | Blue/Orange          | Black/Yellow   |
|             |                |              |                      |                | Ridgeline   | 06-10 Red/Blue | Brown/Black  | Blue/Orange          | Black/Green    |

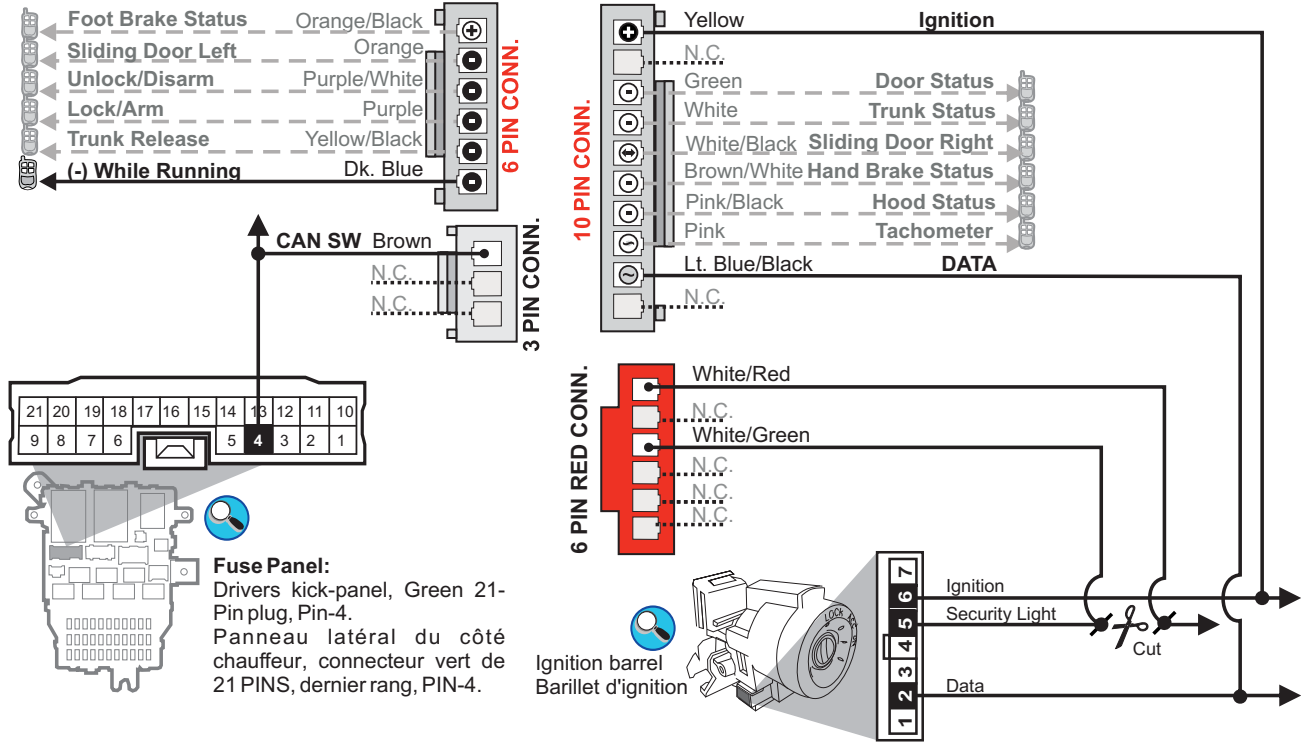

## CONNECTION 2

ACURA / HONDA

PROGRAM: 1

| ACURA YEARS | Data Pin 2     | Security Light Pin 5 | Ignition Pin 6 | HONDA YEARS | Data Pin 2           | Security Light Pin 5 | Ignition Pin 6 |
|-------------|----------------|----------------------|----------------|-------------|----------------------|----------------------|----------------|
| 1.7EL       | 01-05 Red/Blue | Blue/Orange          | Yellow/Black   | Civic / Hyb | 01-05 Red/Blue       | Blue/Orange          | Yellow/Black   |
| MDX         | 03-06 Red      | Pink                 | Green/White    | CR-V        | 02-04 White          | Blue/Orange          | Yellow/Black   |
| RSX         | 02-03 Red/Blue | Blue/Orange          | Yellow/Black   |             | 05-06 White          | Blue/Orange          | Black/Yellow   |
|             | 04-06 Red/Blue | Blue/Orange          | Black/Yellow   | Element     | 03-10 White          | Blue/Orange          | Black/Yellow   |
|             |                |                      |                | Fit         | 06-08 Lt.Green/Black | Red/Black            | Black/Yellow   |
|             |                |                      |                | Pilot       | 05-08 Red/Green      | White/Blue           | Red/White      |
|             |                |                      |                | S-2000      | 04-07 Red/Blue       | Pink                 | Black/Yellow   |

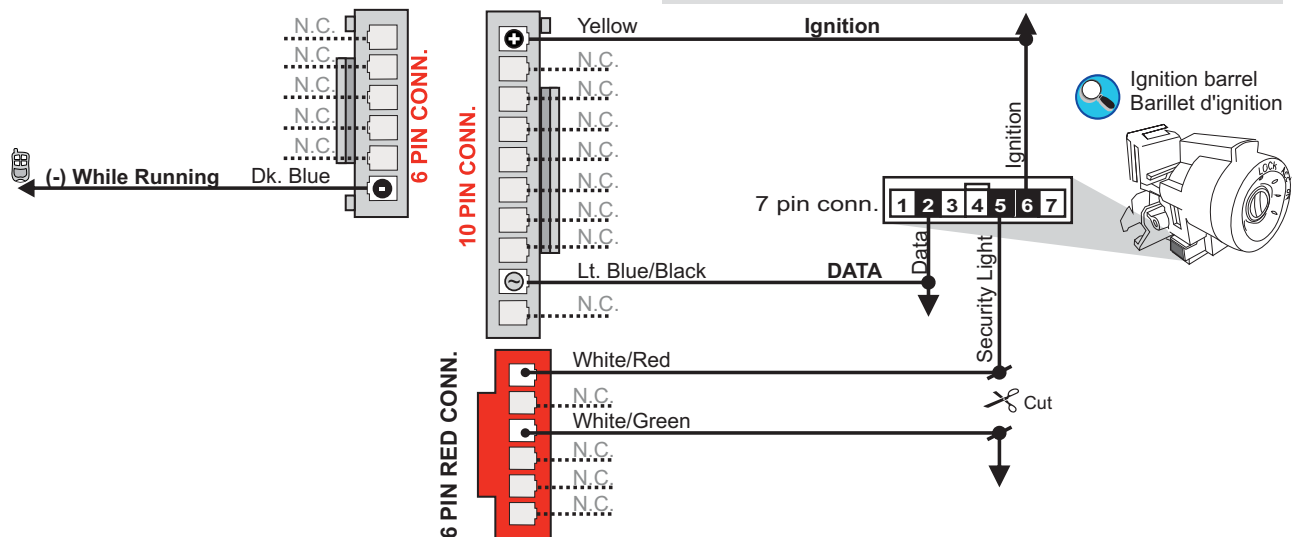

**CONNECTION 3**

ACURA / HONDA

**PROGRAM: 1**

| ACURA YEARS | Ignition Pin 2 | Data Pin 3  | CAN SW Pin 4 |
|-------------|----------------|-------------|--------------|
| MDX 07-10   | Brown          | Light Green | Light Green  |

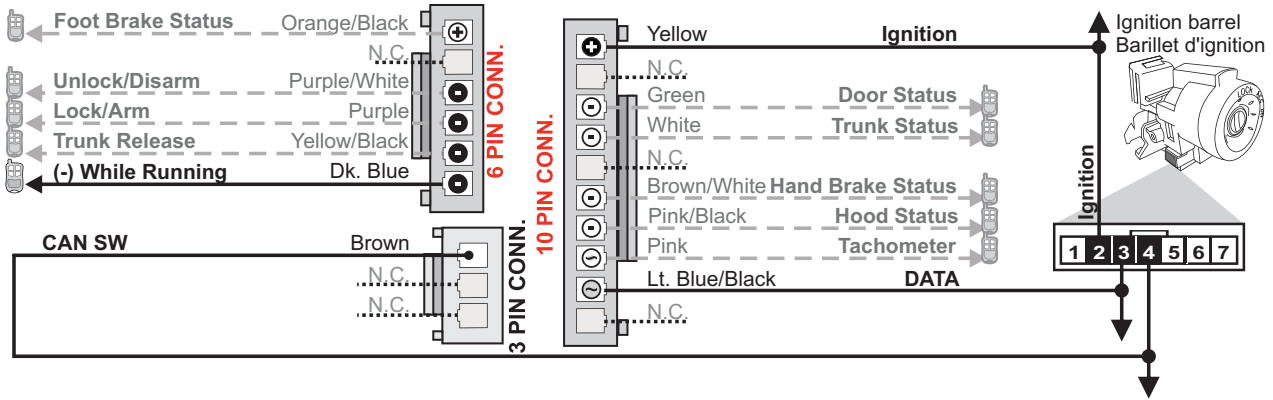

**CONNECTION 4**

ACURA / HONDA

**PROGRAM: 1**

| ACURA YEARS | Ignition Pin 2 | CAN L Pin 3 | CAN H Pin 4 | Data Pin 6  | HONDA YEARS  | Ignition Pin 2 | CAN L Pin 3 | CAN H Pin 4 | Data Pin 6  |
|-------------|----------------|-------------|-------------|-------------|--------------|----------------|-------------|-------------|-------------|
| TL 09-10    | Yellow         | Blue        | Pink        | Light Green | Accord 08-10 | Yellow         | Blue        | Pink        | Light Green |
| TSX 09-10   | Yellow         | Blue        | Pink        | Light Green | Odyssey 11   | Yellow         | Blue        | Pink        | Purple      |
|             |                |             |             |             | Pilot 09-10  | Brown          | Lt Green    | White       | Pink        |

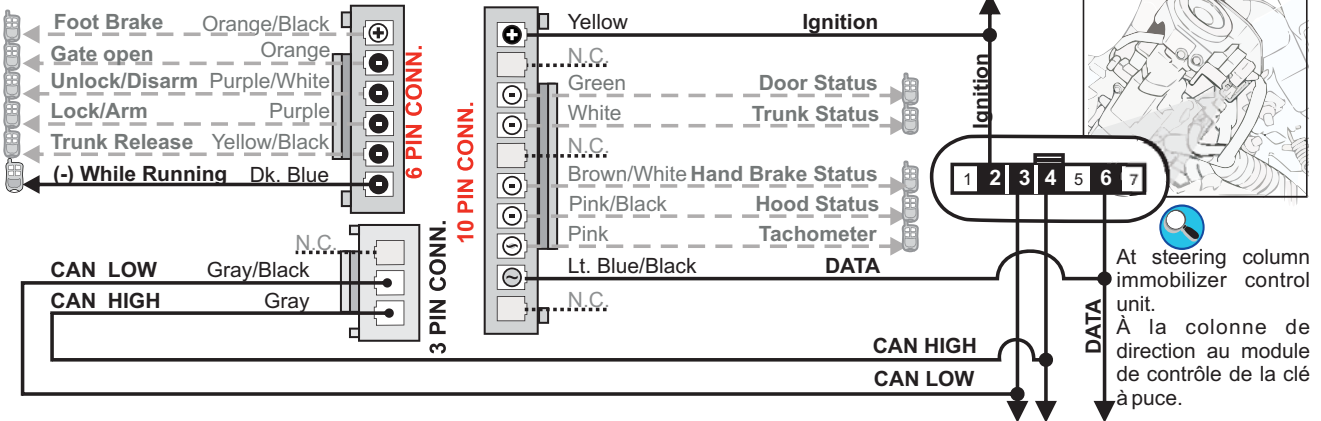

**CONNECTION 5**

ACURA RL & HONDA PRELUDE

**PROGRAM: 1**

| ACURA YEARS | Start Enable Pin 3 | Ignition Pin 4 | Data Pin 6 | HONDA YEARS   | CAN SW Pin 3 | Ignition Pin 4 | Data Pin 6   |
|-------------|--------------------|----------------|------------|---------------|--------------|----------------|--------------|
| RL 98-04    | Pink               | Yellow/Black   | White      | Prelude 97    | Lt Blue      | Black/Yellow   | Brown/Yellow |
|             |                    |                |            | Prelude 98-01 | Lt Blue      | Yellow/Black   | Brown/Yellow |

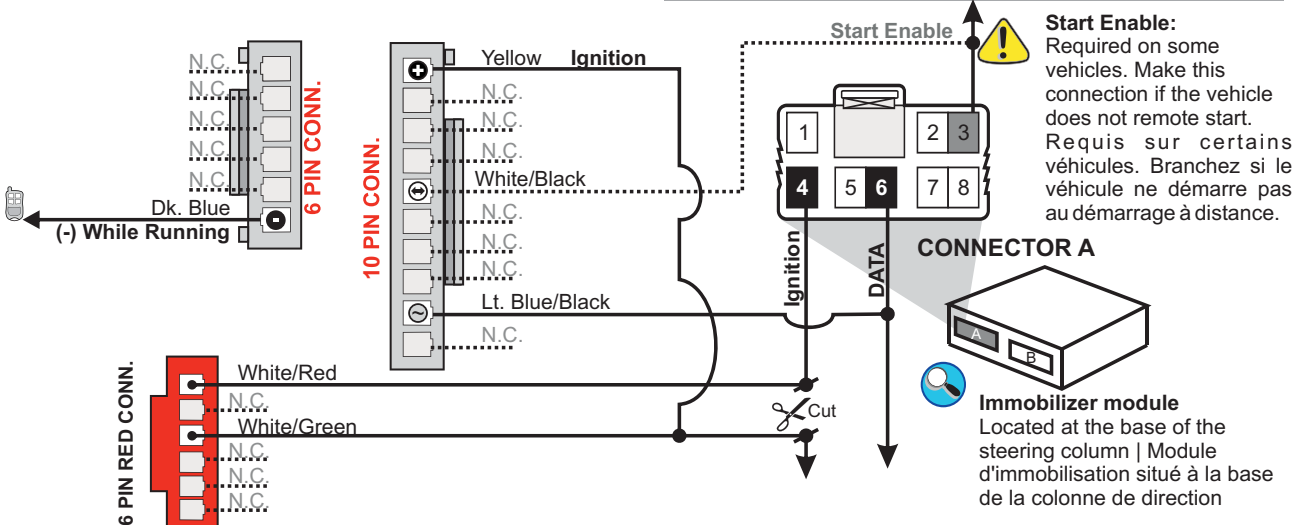

**CONNECTION 6**

**ACURA RL 2005-2010**

**PROGRAM: 1**

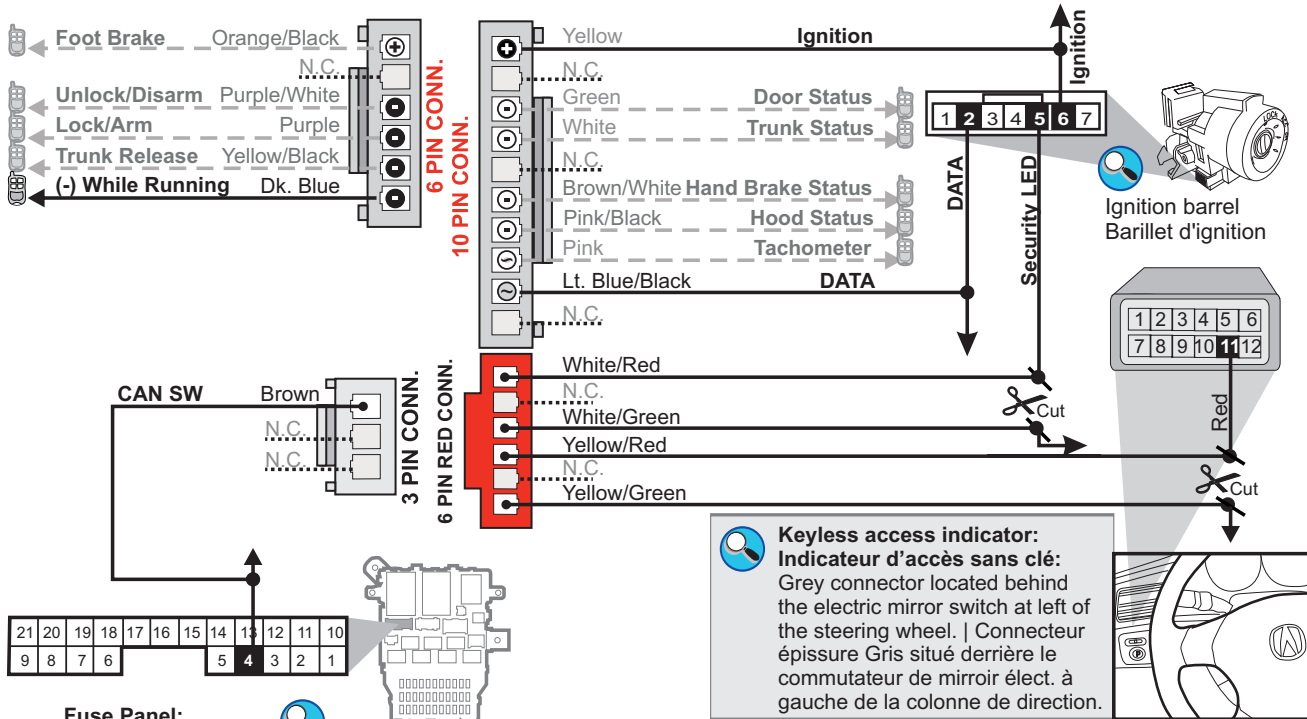

| ACURA | YEARS | Data Pin 2 | Security Light Pin 5 | Ignition Pin 6 |
|-------|-------|------------|----------------------|----------------|
| RL    | 05    | Lt Green   | Blue                 | Pink           |
|       | 06    | Orange     | Red                  | Pink           |
|       | 07-10 | Orange     | Red                  | Pink           |

**CONNECTION 7**

**HONDA CIVIC**

**GO PROGRAM: 1**

| HONDA      | Ignition Pin 2 | CAN Low Pin 3 | CAN High Pin 4 | Data Pin 6 | Unlock | Lock    |
|------------|----------------|---------------|----------------|------------|--------|---------|
| Civic 2012 | Yellow         | Blue          | Pink           | Lt.Green   | Gray   | Lt.Blue |

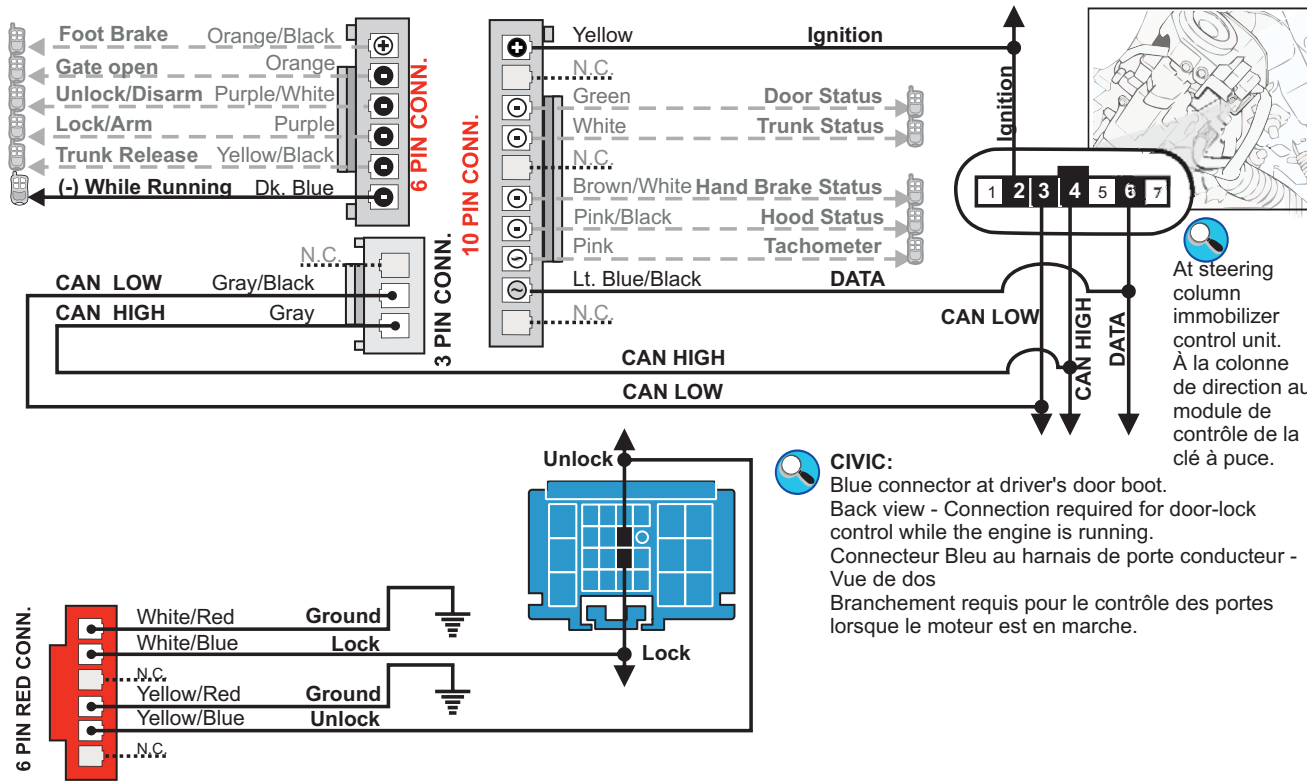

CONNECTION 8

GO PROGRAM: 1

| YEARS        | Ignition Pin 2 | Data Pin 3 | CAN SW Pin 4 | Lock Analog | Unlock Analog | HONDA YEARS | Ignition Pin 2 | Data Pin 3 | CAN SW Pin 4 | Lock Analog | Unlock Analog |
|--------------|----------------|------------|--------------|-------------|---------------|-------------|----------------|------------|--------------|-------------|---------------|
| CSX 06-09    | Yellow         | Lt Green   | Pink         | Green       | Gray          | CR-V 07-10  | Lt Blue        | Green      | Pink         | Blue        | Gray          |
| Civic 06-10  | Yellow         | Lt Green   | Pink         | Green       | Gray          | Fit 09-10   | Red            | Green      | Lt Green     | Lt Blue     | Gray          |
| Hybrid 06-10 | Yellow         | Lt Green   | Pink         | Green       | Gray          | Insight 10  | Red            | Lt Green   | Green        | White       | Green         |

| ACURA YEARS | Ignition Pin 2 | Data Pin 3  | CAN SW Pin 4 |
|-------------|----------------|-------------|--------------|
| RDX 07-10   | Yellow         | Light Green | Pink         |

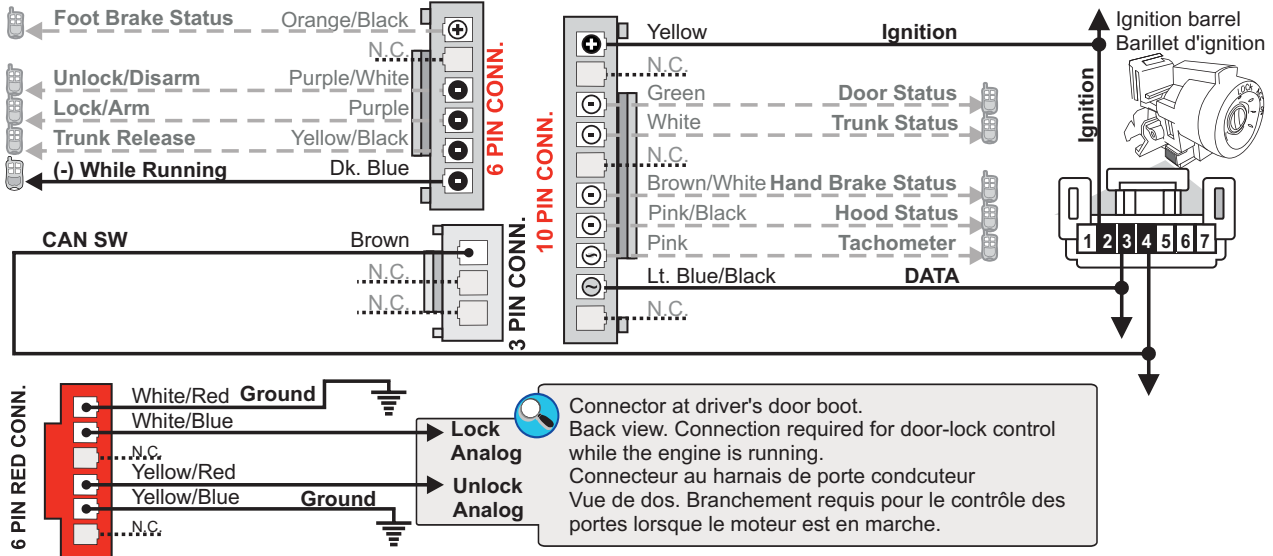

CONNECTION 9

ACURA TL PUSH TO START

GO NEXT PAGE

EVO-CAN Firmware version :2.12 and newer | et plus

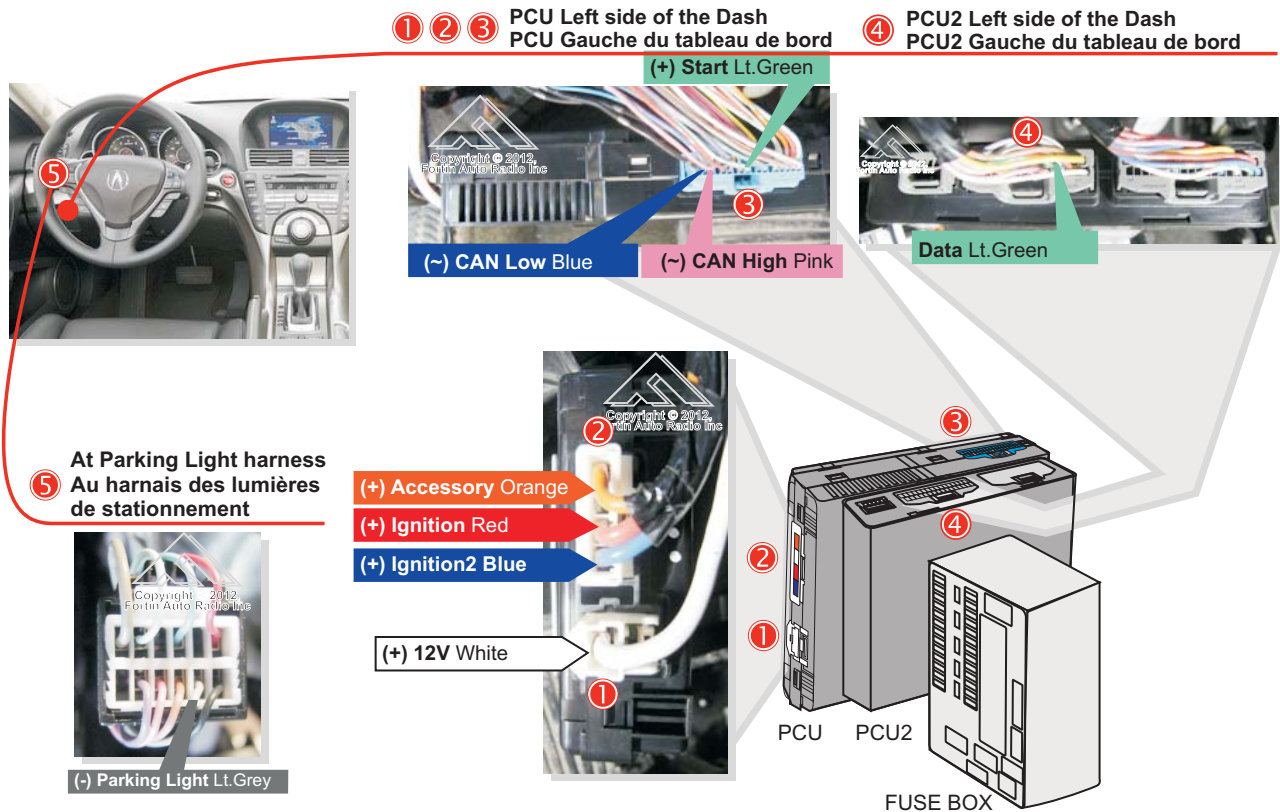

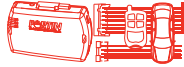

**TL CONTINUED | SUITE**

GO PROGRAM: 2

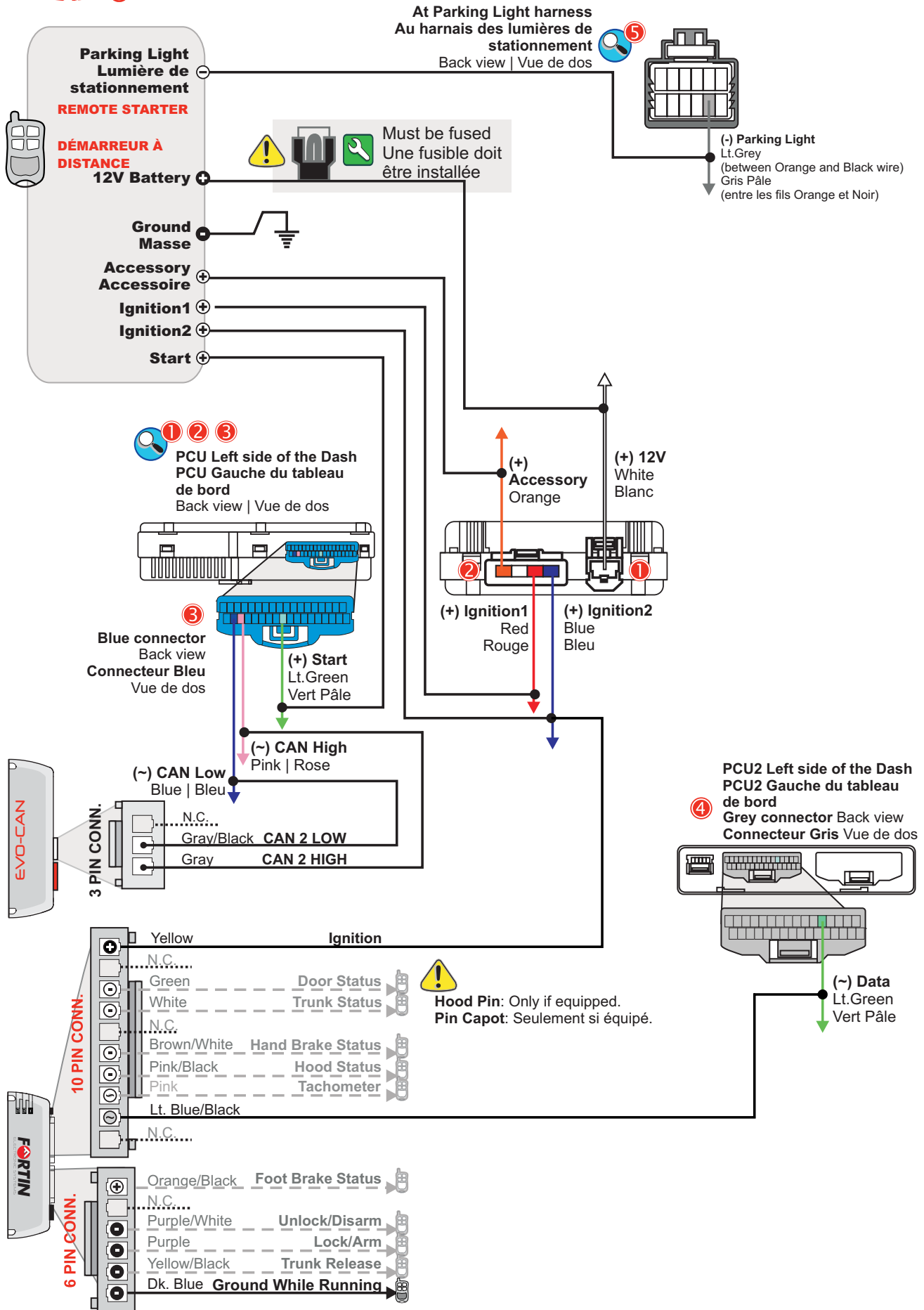

CONNECTION 10

HONDA CRV 2012

GO PROGRAM: 1

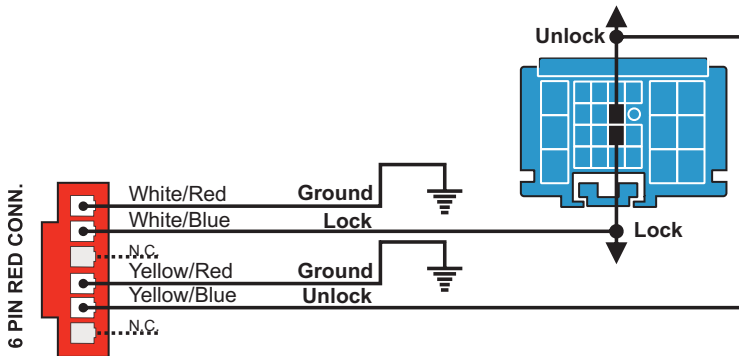
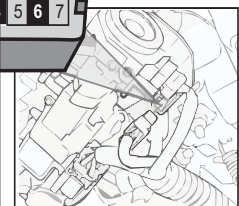
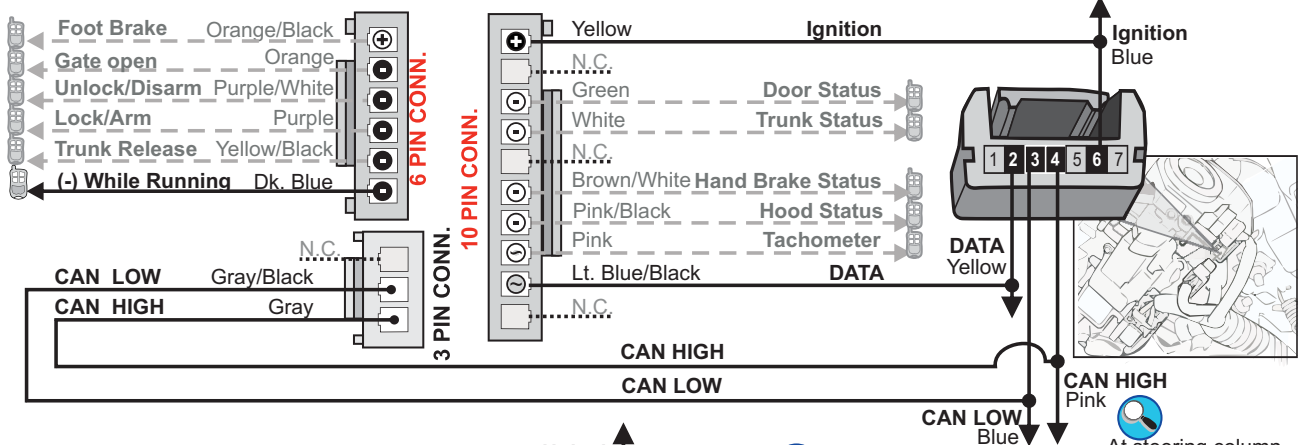

Harness from driver door.  
Harnais provenant de la porte.

Back view - Connection required for door-lock control while the engine is running.  
Connecteur Bleu au harnais de porte conducteur - Vue de dos  
Branchement requis pour le contrôle des portes lorsque le moteur est en marche.



At steering column immobilizer control unit.  
À la colonne de direction au module de contrôle de la clé à puce.





**1 PROGRAMMING PROCEDURE | PROCÉDURE DE PROGRAMMATION**

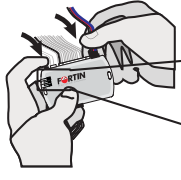
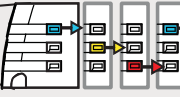
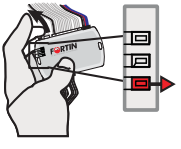
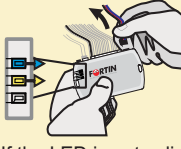
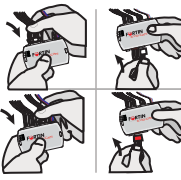

**PROGRAM. 1 HONDA / ACURA**

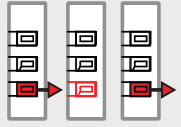
**1**

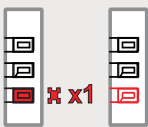
|   |   |  |  |  |   |
|---|---|--|--|--|---|
|  <p><b>Press and hold</b> the programming button:</p> <p><b>Appuyez et maintenir enfoncé</b> le bouton de programmation:</p> |  <p><b>Insert</b> the 4 Pin (Data-Link) connector.</p> <p><b>Insérez</b> le connecteur 4 pins (Data-Link).</p> |  <p>The LED's will alternate between <b>BLUE, YELLOW and RED</b> flashes.</p> <p>Les DELS alternent entre un flash <b>BLEU, JAUNE et ROUGE</b>.</p> |  <p><b>Release</b> the programming button when the LED is <b>RED.</b></p> <p><b>Relâchez</b> le bouton de programmation quand la DEL est <b>ROUGE.</b></p> |  <p>If the LED is not solid <b>RED</b> disconnect the 4 Pin connector (Data-Link) and go back to step 1.</p> <p>Si le DEL n'est pas <b>ROUGE</b> solide débranchez le connecteur 4 pins (Data-Link) et allez à l'étape 1.</p> |  <p><b>Insert</b> the remaining required connectors:</p> <p>10 pin (White), 2 pin (White), 6 pin (White), 6 pin (Red), 3 pin (White).</p> <p><b>Insérez</b> les connecteurs requis restants:</p> <p>10 pins (Blanc), 2 pins (Blanc), 6 pins (Blanc), 6 pins (Rouge), 3 pins (Blanc).</p> |
|---|---|--|--|--|---|

**2**      **3**      **4**

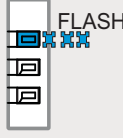
|  |   |  |   |  |   |
|--|---|--|---|--|---|
|  <p><b>Press and release</b> the programming button once (1x).</p> <p><b>Appuyez et relâchez</b> 1 fois le bouton de programmation.</p> |  <p>The <b>RED</b> LED will turn <b>OFF</b> and then back <b>ON</b></p> <p>La <b>DEL ROUGE</b> s'éteint et se rallume.</p> |  <p><b>Press and release</b> the programming button once (1x).</p> <p><b>Appuyez et relâchez</b> 1 fois le bouton de programmation.</p> |  <p>The <b>RED</b> LED will flash <b>1</b> once each second.</p> <p>La <b>DEL ROUGE</b> clignote <b>1</b> fois chaque seconde.</p> |  <p><b>Turn</b> the Ignition to the <b>ON/RUN</b> position.</p> <p><b>Tournez</b> la clef en position <b>ignition (ON)</b>.</p> |  <p>The <b>RED</b> LED will flash rapidly <b>10x</b> times. Key bypass programmed.</p> <p>La <b>DEL ROUGE</b> clignotera <b>10x</b> fois rapidement. Contournement de clé programmé.</p> |
|--|---|--|---|--|---|

|   |   |  |
|---|---|--|
|  <p>The <b>BLUE</b> LED will flash rapidly. <b>CAN-Bus</b> programmed.</p> <p>La <b>DEL BLEU</b> clignotera rapidement: Réseau <b>CAN</b> programmé.</p> |  <p><b>Turn</b> the Ignition to the <b>OFF</b> position.</p> <p><b>Tournez</b> la clef à <b>OFF</b>.</p> |  <p>The module is now programmed.</p> <p>Le module est programmé.</p> |
|---|---|--|

Use the remote of the remote starter or security system to test all of the supported features to ensure proper programming.

Testez toutes les fonctions supportées sur le véhicule avec la télécommande du démarreur à distance ou du système de sécurité.

**PROGRAM. 2**

**ACURA TL**

|  |   |   |   |   |   |
|--|---|---|---|---|---|
| <p><b>1</b></p> <p><b>Press and hold</b> the programming button:</p> <p><b>Appuyez et maintenir enfoncé</b> le bouton de programmation:</p>              | <p><b>Insert</b> the 4 Pin (Data-Link) connector.</p> <p><b>Insérez</b> le connecteur 4 pins (Data-Link).</p> | <p>The LED will alternate between <b>BLUE, YELLOW and RED</b> flashes. Les DELS alternent entre un flash <b>BLEU, JAUNE et ROUGE</b>.</p>                             | <p><b>Release</b> the programming button when the LED is <b>RED</b></p> <p><b>Relâchez</b> le bouton de programmation quand la DEL est <b>ROUGE</b></p> | <p>If the LED is not solid RED disconnect the 4 Pin connector (Data-Link) and go back to beginning of step 1.   Si le DEL n'est pas ROUGE solide débranchez le connecteur 4 pins (Data-Link) et allez au début de l'étape 1.</p>  | <p><b>2</b></p> <p><b>Insert</b> the remaining required connectors: 10 pin (White), 2 pin (White), 6 pin (White), 6 pin (Red), 3 pin (White),</p> <p><b>Insérez</b> les connecteurs requis restants: 10 pins (Blanc), 2 pins (Blanc), 6 pins (Blanc), 6 pins (Rouge), 3 pins (Blanc),</p> |
| <p><b>3</b></p> <p><b>Press</b> the programming button once (1x).</p> <p><b>Appuyez et relâchez</b> 1 fois le bouton de programmation.</p>               | <p>The RED LED will turn <b>OFF</b> and turn back <b>ON</b>.</p> <p>La DEL ROUGE s'éteint et se rallume.</p>  | <p><b>4</b></p> <p><b>Press</b> the programming button once (1x).</p> <p><b>Appuyez et relâchez</b> 1 fois le bouton de programmation.</p>                            | <p>The RED LED will flash 1 once every second.</p> <p>La DEL ROUGE clignote 1 fois chaque seconde.</p>  | <p><b>Press</b> the Push-to-Start button twice to turn on the ignition. (Do not press the brake pedal)</p> <p><b>Appuyez</b> 2 fois sur le bouton démarrage (Push-to-Start) pour allumer l'ignition. (Ne pas appuyer sur la pédale de frein)</p>  |   |
| <p>The Red LED will flash 10 times, Key bypass : programming complete. La DEL Rouge clignote 10 fois : Contournement de clé: programmation complété.</p> | <p>Once the Blue LED starts to flash rapidly: Lorsque la DEL Bleu clignote rapidement:</p>                    | <p><b>press</b> the Push-to-Start button once to shut off the ignition. <b>appuyez</b> une fois sur le bouton démarrage (Push-to-Start) pour éteindre l'ignition.</p> | <p>The LED will turn off. Le DEL s'éteint.</p>  | <p>The module is now programmed. Le module est programmé.</p> <p>Use the remote of the remote starter or security system to test all of the supported features to ensure proper programming. Testez toutes les fonctions supportées sur le véhicule avec la télécommande du démarreur à distance ou du système de sécurité.</p> |   |

**REMOTE STARTER FUNCTIONALITY | FONCTIONNALITÉS DU DÉMARREUR À DISTANCE**

|   |   |   |  |  |   |  |
|---|---|---|--|--|---|--|
| <p>All doors must be closed. Toutes les portes doivent être fermées</p> | <p><b>Remote start</b> the vehicle. <b>Démarrez</b> à distance.</p> | <p>The module will shut down the vehicle as soon as the drivers door is opened. Lors de l'ouverture de la porte conducteur le véhicule s'éteindra par sécurité.</p> | <p><b>Enter</b> the vehicle with the Smart-Key. <b>Entrez</b> dans le véhicule avec la clé intelligente (Smart-Key) sur vous</p> | <p><b>Press</b> the brake pedal. <b>Appuyez</b> sur la pédale de frein</p> | <p><b>Press</b> the Push-to-Start button once. <b>Appuyez</b> 1 fois sur le bouton démarrage (Push-to-Start).</p> | <p>The vehicle can now be put in to gear and driven. Vous êtes maintenant prêt à embrayer et prendre la route.</p> |
|---|---|---|--|--|---|--|

# EVO-CAN

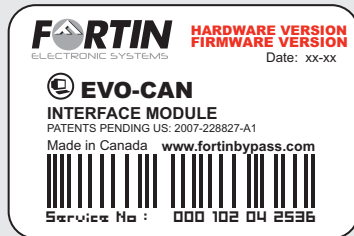
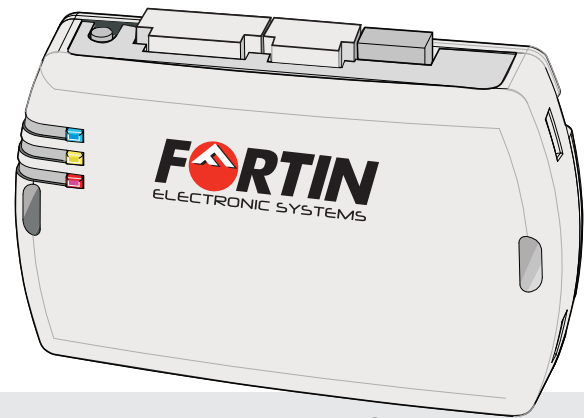

Module label | Étiquette sur le module

## **Notice:** Updated Firmware and Installation Guides

**Updated firmware and installation guides** are posted on our web site on a regular basis. We recommend that you update this module to the latest firmware and download the latest installation guide(s) prior to the installation of this product.

**Des mises à jour du Firmware (microprogramme) et des guides d'installation** sont mises en ligne régulièrement. Vérifiez que vous avez bien la dernière version logiciel et le dernier guide d'installation avant l'installation de ce produit.

## **WARNING / TECH SUPPORT / MISE EN GARDE / SUPPORT TECHNIQUE**

The information on this sheet is provided on an (as is) basis with no representation or warranty of accuracy whatsoever. It is the sole responsibility of the installer to check and verify any circuit before connecting to it. Only a computer safe logic probe or digital multimeter should be used. FORTIN ELECTRONIC SYSTEMS assumes absolutely no liability or responsibility whatsoever pertaining to the accuracy or currency of the information supplied. The installation in every case is the sole responsibility of the installer performing the work and FORTIN ELECTRONIC SYSTEMS assumes no liability or responsibility whatsoever resulting from any type of installation, whether performed properly, improperly or any other way. Neither the manufacturer or distributor of this module is responsible of damages of any kind indirectly or directly caused by this module, except for the replacement of this module in case of manufacturing defects. This module must be installed by qualified technician. The information supplied is a guide only. This instruction guide may change without notice. **Visit [www.fortinbypass.com](http://www.fortinbypass.com) to get the latest version.**

L'information de ce guide est fournie sur la base de représentation (telle quelle) sans aucune garantie de précision et d'exactitude. Il est de la seule responsabilité de l'installateur de vérifier tous les fils et circuit avant défectuer les connections. Seule une sonde logique ou un multimètre digital doivent être utilisés. FORTIN SYSTÈMES ÉLECTRONIQUES n'assume aucune responsabilité de l'exactitude de l'information fournie. L'installation (dans chaque cas) est la responsabilité de l'installateur effectuant le travail. FORTIN SYSTÈMES ÉLECTRONIQUES n'assume aucune responsabilité suite à l'installation, que celle-ci soit bonne ou mauvaise ou de n'importe autre type. Ni le fabricant, ni le distributeur ne se considèrent responsables des dommages causés ou ayant pu être causés, indirectement ou directement, par ce module, excepté le remplacement de ce module en cas de défectuosité de fabrication. Ce module doit être installé par un technicien qualifié. L'information fournie dans ce guide est une suggestion. Ce guide d'instruction peut faire l'objet de changement sans préavis. **Consultez le [www.fortinbypass.com](http://www.fortinbypass.com) pour voir la plus récente version.**

Copyright © 2006-2011, FORTIN AUTO RADIO INC ALL RIGHTS RESERVED **PATENT PENDING**



### **TECH SUPPORT**

Tél: 514-255-HELP (4357)  
1-877-336-7797



### **ADDENDUM GUIDE**

**[www.fortinbypass.com](http://www.fortinbypass.com)**  
WEB UPDATE | MISE À JOUR INTERNET

